



NVIDIA GRID VCA

WITH GRID SOFTWARE VERSION 1.5

DU-06922-015_v03 | December 2014

Installation and Setup



TABLE OF CONTENTS

Introduction to NVIDIA GRID VCA	6
Description of The Appliance	7
GRID VCA Schematic	8
What's New in GRID VCA 1.5	8
GRID VCA Specifications	9
Mechanical	9
Front Panel LED	9
Connections	10
Software Overview	11
GRID VCA Setup Console	12
Client Setup	13
Operator Console	14
Hardware Installation	15
What's in the Box	16
Rack Mounting	16
Choosing a Setup Location	16
Installing the GRID VCA into a Rack	17
Connecting power and Ethernet	18
Network Setup and Activation	20
Preparing for Network Setup & Activation	21
Network Requirements	21
Port Requirements	22
Windows Product Key	23
Networking Setup & Activation	24
Editing Network Information	25
Activating Windows	27
Optional Settings	29
Modifying the Internal Network Addressing Scheme	29
Configuring an Intelligent Platform Management Interface (IPMI)	31
Exporting and Importing the Template	36
Installing the GRID Workspace Client	41
System Requirements	42
Operating System	42
Hardware	42
End User License Agreement	43
Installation Instructions	44
Microsoft Windows	44
Linux	49
Apple Mac OS	54
Using The GRID Workspace Client	58
Opening the GRID Workspace	59

Closing the GRID Workspace	60
Navigating the GRID Workspace	61
Working with the Workspace	61
The Title Bar	62
Configuring GRID Client Settings	65
Basic Tab	67
Experience Tab	68
Advanced Tab	70
Shortcuts Tab	71
The GRID VCA Web Interface	72
the GRID Operator Console	73
Overview Page	74
Deployment	75
Current Software Tab	75
Install Updates Tab	76
Logs Tab	76
Allocation Status	77
Configuration	78
Maintenance	80
Maintenance Mode	80
Maintenance Controls	83
Using Multiple GPUs per Seats	84
Notifications	86
Audit Log	87
Operator Accounts	88
Common Administrative Tasks	90
Installing Applications On the Template Workspace	91
Connecting to the GRID VCA Using VNC	92
Summary of Steps	92
Detailed Instructions	92
Installing the GRID Image From a USB Drive	95
Setting Up Active Directory Authentication	98
Connecting to the GRID VCA Remotely	99
Using SSH	99
Using IPMI	99
Deploying a New Manifest	100
Preserving User Settings	101
Adding File and Directory Locations	103
Adding Registry Locations	104
Saving Changes	105
Common Client Tasks	106
Copying Files into the GRID Workspace	107
Proper Use of Data Storage	108
Best Practices and Known Issues	109
Best Practices for Users	110

Best Practices for Administrators	110
Actions to Avoid	111
General	111
Hardware	111
GRID Workspace Client.....	111
GRID Workspace Template	111
GRID Maintenance	112
Hypervisor	112
Known Issues.....	113
Windows Updates or antivirus software may conflict with the template workspace.....	113
Two cursors appear when increasing Adobe Photoshop brush size.	113
Compliance	114
United States	115
Industry Canada (IC).....	116
European Union	116
Australia & New Zealand	116
Japan	117
Korea	117
Taiwan Compliance.....	118
Safety.....	118

LIST OF FIGURES



Figure 1 Installing the VCA Into a Rack	17
Figure 2 Connecting Ethernet Cable from LAN Port to Ethernet Switch	19
Figure 3 Connecting Network Cables from VCA to Ethernet Switch	19

LIST OF TABLES

Table 1. Ports and Types of Data	22
Table 2. Account Roles	89

CONVENTIONS USED IN THIS DOCUMENT

This document uses the following conventions:

 CAUTION: Indicates information that must be observed to avoid bodily injury.
 Note: Indicates additional helpful information.
1. Numbered steps are used to indicate the order in which instructions are to be followed.
► Bulleted items are used to indicate a list of items in no particular order.
Bold text indicates names of software files, controls, and buttons – especially where some action upon them is indicated.
<i>Italic text</i> is used for labels, such as names of windows, dialog boxes, or tabs.

INTRODUCTION TO NVIDIA GRID VCA

DESCRIPTION OF THE APPLIANCE



The NVIDIA GRID™ Visual Computing Appliance (VCA) is an NVIDIA-built 4-rack unit appliance. NVIDIA virtualization software allows the appliance to run fully GPU-accelerated Windows 7 applications for up to 8 users.

NVIDIA streaming software delivers a high-quality low-latency remote graphics experience. The graphics output of the applications running on the VCA is streamed over the LAN to any Mac OS X, Red Hat Enterprise Linux (RHEL), or Windows 7 desktop running a small application called the GRID Workspace client.

The GRID VCA contains a Windows 7 Template Workspace that is maintained just like a typical workstation. Each time a user connects to the VCA they are given a brand new copy (cloned seat) of the Template Workspace. In this way, up to 8 simultaneous Windows 7 workspaces can be set up to run on the appliance. Each copy is created on demand and destroyed after it is used.

Each cloned seat has access to all of the resources in the system including an NVIDIA® Quadro® K5000-class GPU. GRID Workspaces, therefore, deliver high-end workstation-class performance on very light clients like a MacBook Air.

GRID VCA SCHEMATIC

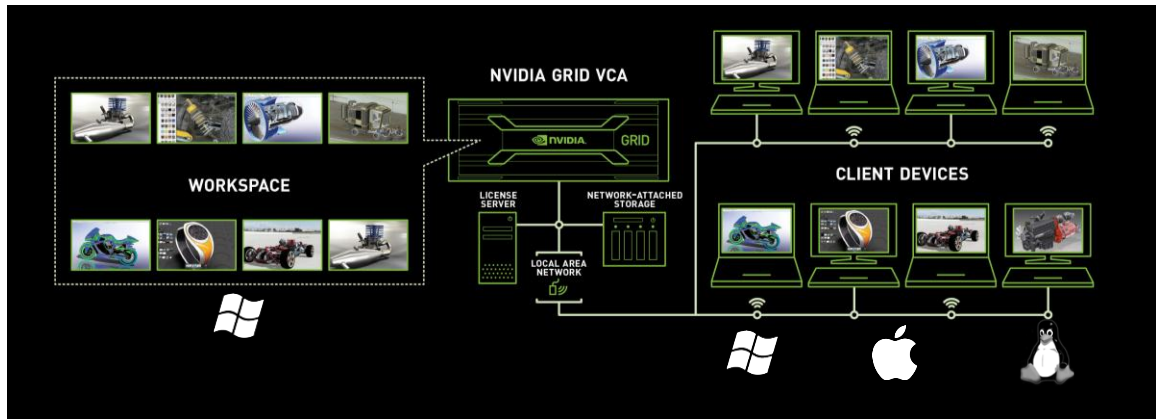

- ▶ 8 simultaneous Windows 7 workspaces run inside the GRID VCA using the resources in the system.
- ▶ The display from the Windows 7 workspace is delivered to a Windows, Mac, or Linux machine on the LAN while mouse and keyboard commands are sent from the client device to the GRID workspace.
- ▶ Application data should be stored on a network-attached storage that is connected to the GRID VCA.
- ▶ All application software that you plan to run on the GRID VCA should use a floating network license.

WHAT'S NEW IN GRID VCA 1.5

- ▶ Active Directory can be used to control access to the VCA.
- ▶ Fixed some dropped connection issues.
- ▶ Implemented automatic reconnection in the event of disconnect.
- ▶ New full-screen mode top menu bar added to the Workspace Client (Windows only).
- ▶ Improved connection reliability when connecting to the GRID VCA while in maintenance mode.
- ▶ Moved the Internal network switch setting from the Operator Console to the Setup Console.
- ▶ Added bandwidth used (Mbps) to the frames per second display on the Workspace Client.

GRID VCA SPECIFICATIONS

Mechanical

Feature	Description
Form Factor	4U Rackmount
Height	7.0" (178mm)
Width	18.2" (462mm)
Depth	26.5" (673mm)
Gross Weight	70.4 lbs (31.9 kg)
Color	Dark Gray

Front Panel LED

LED Behavior	Status
Steady	System is good
Blinking	Unit ID, Fan Failure, Power Failure, Overheat

Connections

Power

The GRID VCA comes with 1620 W Redundant Platinum Level high efficiency power supplies. The power supplies can accept either 120 V (ac) or 240 V (ac).

VCA Input		Specification for Each Power Supply	Comments
240 V (ac)	1475 W max.	1620 W @ 180-240 V, 10.5-8 A, 50-60 Hz	Provides power redundancy. In the event of a power supply failure, the redundant power supply continues to power the system even under overvoltage fault.
120 V (ac)		1000 W @ 100-120 V 1200 W @ 120-140 V, 12-10 A, 50-60 Hz	Load is balanced between both power supplies. No redundancy is available.

Ports

Type	Description
VGA	One VGA port connects to a VGA capable monitor and displays the GRID VCA setup console.
USB	Two USB 2.0 ports are available to connect to a keyboard. A keyboard is required for navigating the GRID VCA setup console.
Ethernet	<p>One IPMI Ethernet Port. The Intelligent Platform Management Interface (IPMI) port can optionally be used to monitor and manage the system in place of a local keyboard and monitor.</p> <p>Two 1Gb Ethernet Ports. These are not used.</p> <p>Two 10Gb Ethernet Ports. One of these Ethernet ports is used for all network traffic.</p>

SOFTWARE OVERVIEW

The GRID VCA uses several software interfaces for setting up the host appliance, configuring the GRID client, and managing the operation of the entire GRID system.

The three software interfaces are

- ▶ [GRID VCA Setup Console](#)
- ▶ [Client Setup](#)
- ▶ [Operator Console](#)

GRID VCA Setup Console

Purpose

The GRID VCA Setup Console is used to configure the network as well as to activate Windows during the initial setup. It is not needed during everyday operation and maintenance.

```

Status
Configure VCA Networking
Change Hostname
Activate Windows
Save/Restore Template Image
Configure IPMI Networking
Virtual Machines
Hardware and BIOS Information
Reboot or Shutdown
Local Command Shell
Quit

NVIDIA
GRID Visual Computing Appliance

Version          1.5.086
Current Mode     Maintenance Mode

Hostname         UCA-MASTER
Hypervisor IP   10.31.200.76
Appliance IP    10.31.200.77

Netmask          255.255.252.0
Gateway         10.31.200.1
Domain Name
Name server (DNS) 10.31.200.11
                 208.67.220.220

<F5> Refresh <Page Up/Down> Scroll

```

How to Access Directly

To access and use the GRID VCA Setup Console, connect a display to the VGA connector and a keyboard to any of the USB ports, and then press the power button.

How to Access Using SSH

You can access the GRID VCA Setup Console remotely using the secure shell (SSH) protocol. You will need to install SSH client software.

1. Launch the SSH Client software.
2. Connect using the following address and credentials:
 - Host Name or IP Address: :<GRID Appliance IP>
 - User: gridadmin
 - Pass: xenserver
3. Once connected, use the `sudo xsconsole` command to launch the Setup Console.

Client Setup

Purpose

The *GRID VCA Connection Settings* dialog lets users customize their GRID Workspace Client after installation. The dialog opens the first time you attempt to open the GRID Workspace Client in order to set up basic connection settings.

How to Access

From the GRID Workspace Client, click the Settings icon at the upper left corner of the workspace, then select **Show Settings Dialog**.

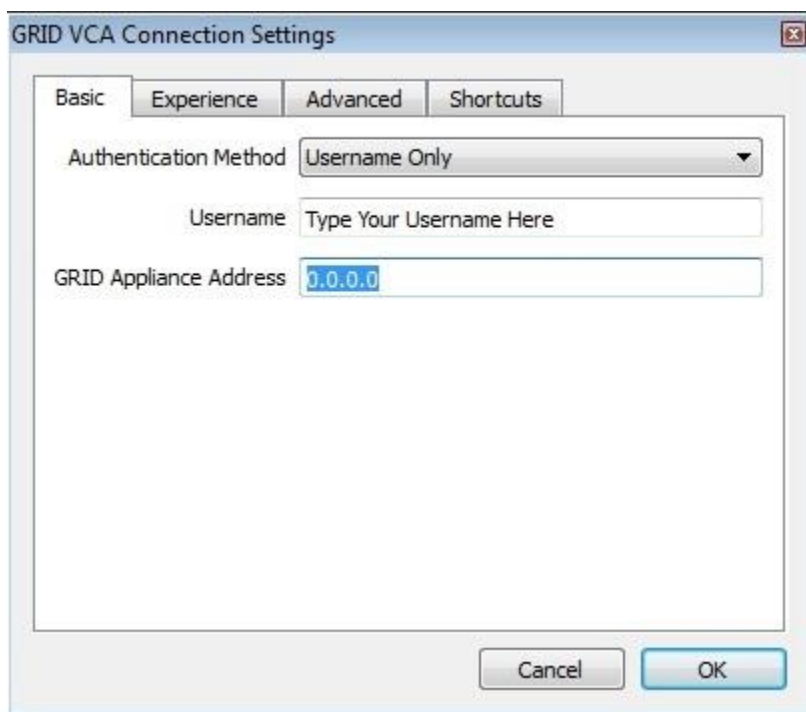

Operator Console

Purpose

The Operator Console is a web-based console that lets administrators manage and monitor the following GRID VCA features:

- ▶ Service Usage
- ▶ Seat Status
- ▶ GRID Software Deployment
- ▶ Zone configuration, including concurrent session limits, disconnect timeouts, console timeouts, etc.
- ▶ Maintenance Mode
- ▶ Operator Accounts

How to Access

1. Open the Operator Console for the GRID VCA Appliance in your browser by going to the URL `http://<GRID Appliance IP>:444`.

Alternately, go to `http://<GRID Appliance IP>` to open the *Set Up NVIDIA GRID Workspace* page and then click **Manage NVIDIA GRID**.

2. At the Login screen, sign in with the following credentials:

- Username: admin
- Password: test

The Operator Console opens to the *Overview* page.

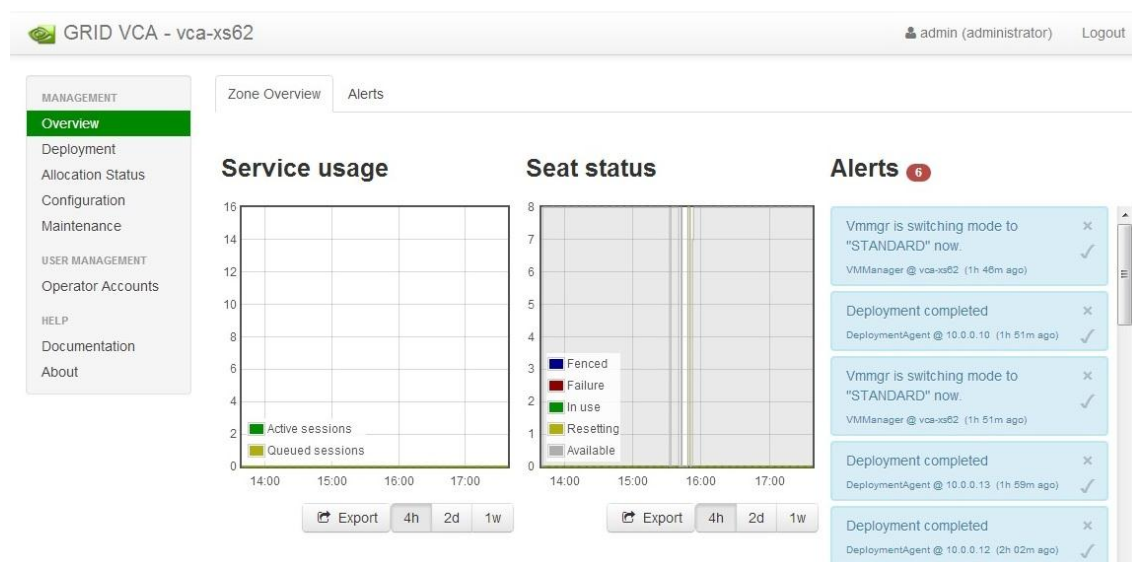

HARDWARE INSTALLATION

WHAT'S IN THE BOX

Be sure to inspect each piece of equipment shipped in the packing box. If anything is missing or damaged, contact your supplier.

What's included with your NVIDIA GRID Visual Computing Appliance:

- ▶ Welcome card
- ▶ Power cables (2)
- ▶ NVIDIA GRID VCA (with rails for rack mounting)

RACK MOUNTING

This section provides instructions on how to rack mount and connect your NVIDIA GRID VCA. Following the steps in the order given should enable you to have the system operational within a minimal amount of time.

Choosing a Setup Location

Decide on a suitable location for setting up and operating the NVIDIA GRID VCA. It should be situated in a clean, dust-free area that is well ventilated. Avoid areas where heat, electrical noise, and electromagnetic fields are generated. You will also need it placed near a grounded power outlet.

- ▶ Leave enough clearance in front of the rack to enable you to open the front door completely (~25").
- ▶ Leave approximately 30" of clearance in the back of the rack to allow for sufficient airflow and ease in servicing.
- ▶ Always make sure the rack is stable before extending the GRID VCA or any other component from the rack.
- ▶ Keep the ambient temperature and humidity within the following ranges:
 - Temperature: 10°C to 35°C (50°F to 95°F)
 - Humidity: 8% to 90% (non-condensing)

Installing the GRID VCA into a Rack

Precautions



CAUTION: To prevent bodily injury when mounting or servicing the GRID VCA in a rack, you must take special precautions to ensure that the system remains stable. The following guidelines are provided to ensure your safety.

- ▶ The VCA should be mounted at the bottom of the rack if it is the only unit in the rack.
- ▶ When mounting the VCA in a partially filled rack, load the rack from the bottom to the top with the heaviest component at the bottom of the rack.
- ▶ If the rack is provided with stabilizing devices, install the stabilizers before mounting or servicing the VCA in the rack.

Installing the Outer Rails

1. Adjust the brackets to the proper distance so that the rail fits snugly into the rack.
2. Secure the rear of the outer rail with two M5 screws and the rear of the rack.



Note: The outer rail is adjustable from approximately 26" to 38.25."

3. Repeat steps 1-2 for the left outer rail.

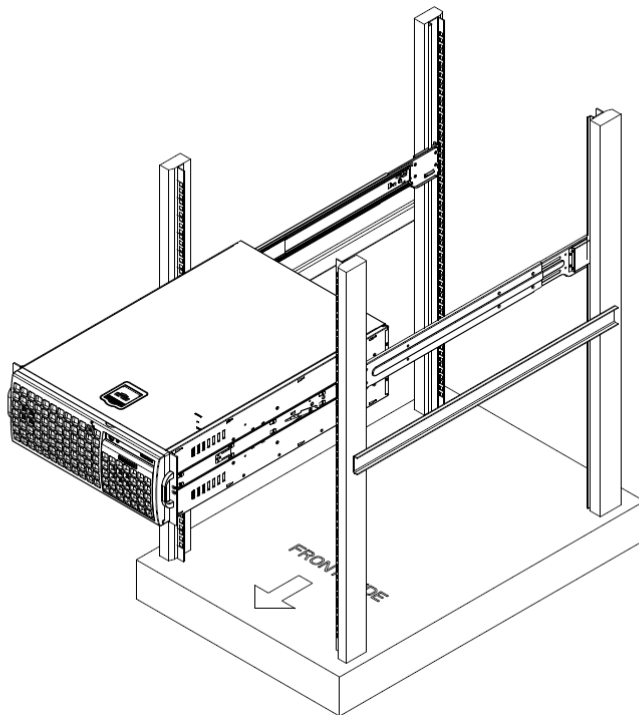

Figure 1 Installing the VCA Into a Rack

Installing the GRID VCA

1. Confirm that the VCA has the inner rails attached and that you have already mounted the outer rails into the rack.
2. Align the inner chassis rails with the front of the outer rack rails.
3. Slide the inner rails into the outer rails, keeping the pressure even on both sides (you may have to depress the locking tabs when inserting). When the VCA has been pushed completely into the rack, you should hear the locking tabs “click” into the locked position.



CAUTION: Stability hazard: The rack stabilizing mechanism must be in place, or the rack must be bolted to the floor before you slide the VCA out for servicing. Failure to stabilize the rack can cause the rack to tip over.



Note: The rail assemblies shipped with the GRID VCA fit into a standard 19" rack.

CONNECTING POWER AND ETHERNET

1. Connect the two power cables shipped in the kit from each connector to either a 120 V (ac) or 240 V (ac) outlet.
240 V is recommended for power redundancy in the event one of the power supplies fails.
2. Connect a VGA monitor to the VGA connector on the appliance.
3. Connect a keyboard, using any of the front or back USB ports.



Note: The VGA monitor and keyboard are used during initial setup and are not needed during normal operation.

4. Using *only* the LAN Port indicated in Figure 2, connect an Ethernet cable from the LAN Port to an Ethernet switch. (The LAN Port indicated is 10 Gb– and 1 Gb–capable and is located on the add-in card.)

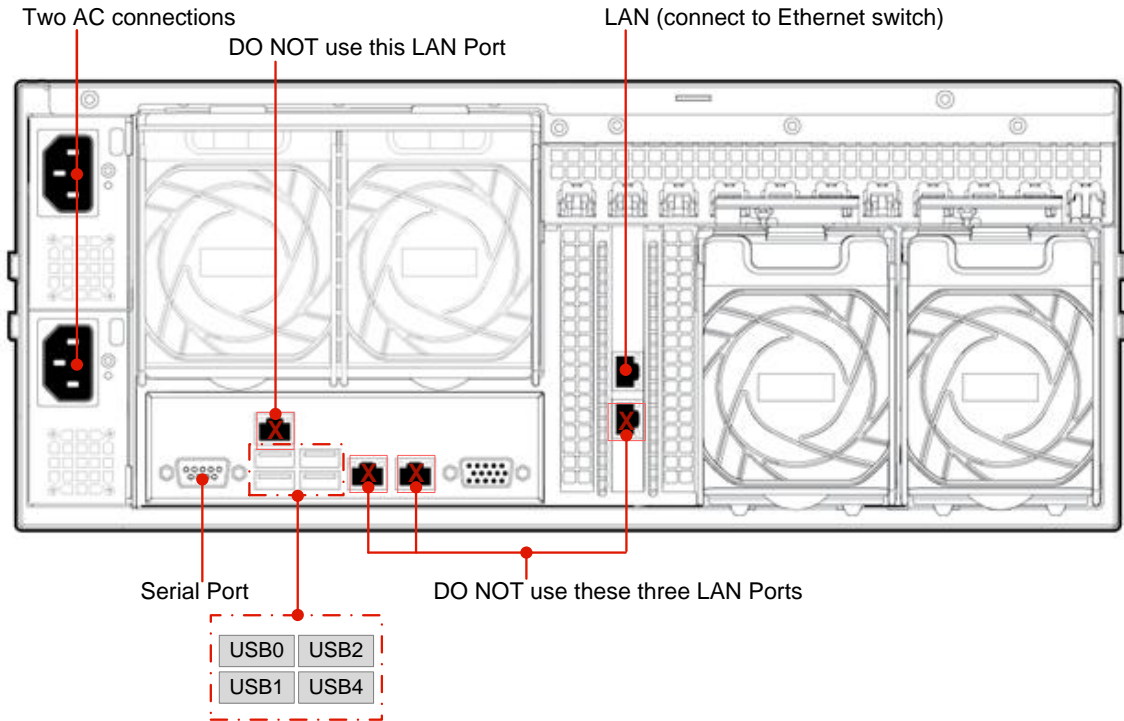

Figure 2 Connecting Ethernet Cable from LAN Port to Ethernet Switch

5. Connect the network cables from the NVIDIA GRID VCA to a data center network Ethernet switch, using a Cat5, Cat5e, or Cat6 Ethernet cable (See Figure 3).

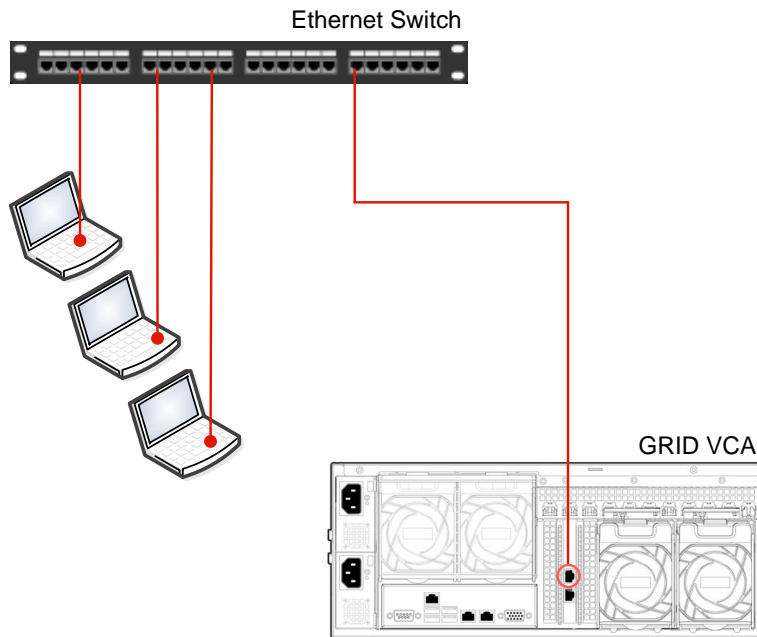

Figure 3 Connecting Network Cables from VCA to Ethernet Switch

NETWORK SETUP AND ACTIVATION

The GRID VCA is a network appliance, and requires network configuration in order to work on your network. Once the appliance is configured to your network settings, users on your network can connect to the appliance and request a workspace. This section provides instructions on how to configure networking on the GRID VCA and how to activate the Windows licenses for your GRID VCA.

PREPARING FOR NETWORK SETUP & ACTIVATION

Network Requirements

To install the GRID VCA on your network, you need to collect the following information.

▶ Two static IP addresses

- Hypervisor IP: The hypervisor is an operating system that controls the virtual machines that run on the GRID VCA. Once assigned, this IP address is used only for troubleshooting and will not be used on a daily basis.
- GRID Appliance IP: This is the most important IP address for your GRID VCA. You and all users will use this address to connect to and manage the appliance.

▶ Gateway address

The gateway, or router, is the network address to bridge the local subnet to outside networks. This address is usually provided by your Internet service provider or IT department. You can find the gateway information for your network by using the “ipconfig” command on Windows, or “route -n” command on Linux and looking for “Default Gateway” (be sure to run those commands on a system that is on the same network as the GRID Appliance).

▶ Subnet mask

The subnet mask is a networking parameter that specifies what addresses are visible on the local network, without having to be routed to an outside network. This parameter is usually provided by your Internet service provider or IT department. You can find the subnet mask for your network by using the “ipconfig” command on Windows, or “route -n” command on Linux (be sure to run those commands on a system that is on the same network as the GRID Appliance).

► DNS address

The domain name server (DNS) translates alphanumeric hostnames into IP addresses. The DNS is typically provided by your Internet service provider or by your company's IT department. It is important to get the correct DNS address because it ensures the appliance is able to connect to the Internet and other hosts on your network.

► Address of the license manager for your applications

GRID VCA requires a floating network license for the licensed applications you will install and run in the appliance. With a floating license there is a central repository, on the network, where the software license is kept. Users "check out" or "borrow" a license from the server, use it, and then "return it" or "check it in" so that someone else can use that license. You will need the address of this license server when installing your licensed applications.

Port Requirements

The GRID VCA uses specific ports for various types of communication. Make sure these ports are open and available on your firewall to the GRID VCA and any client connecting to the GRID VCA. Table 1 lists the ports and types of data sent through each port.

Table 1. Required Ports for Opening a Client Workspace

Port (Protocol)	Use
80 (TCP)	Client download
443 (TCP)	Client connections to the desktop
10000 - 10100 (TCP/UDP)	Streaming ports

The ports listed in Table 2 are used for auxiliary functions, such as debugging, testing, or accessing the operator console. While not needed for general connectivity, those ports will need to be open before attempting any of those functions.

Table 2. Optional Ports for Auxiliary Functions

Port (Protocol)	Use
444 (TCP)	Access to the Operator Console Web interface
5001 (TCP/UDP)	Used by the client to check network speed
30021 - 30026 (for VNC)	VNC debugging ports

Windows Product Key

You will need the Windows product key in order to activate Windows. Record the product key from any two of the Windows product stickers located on the top of the GRID VCA chassis.



Note: There are nine Windows product stickers on the chassis to cover all of the Windows licenses used in the box. However, for the purposes of activating Windows, you only need to enter the information from two of the stickers.

NETWORKING SETUP & ACTIVATION

Use the GRID VCA setup console to configure the network as well as to activate Windows. Connect a keyboard to the GRID VCA so you can navigate the setup console, which is displayed on the VGA output of the GRID VCA.

```

Status
Configure VCA Networking
Change Hostname
Activate Windows
Save/Restore Template Image
Configure IPMI Networking
Virtual Machines
Hardware and BIOS Information
Reboot or Shutdown
Local Command Shell
Quit

NVIDIA
GRID Visual Computing Appliance

Version          1.5.086
Current Mode     Maintenance Mode

Hostname         VCA-MASTER
Hypervisor IP   10.31.200.76
Appliance IP    10.31.200.77

Netmask          255.255.252.0
Gateway          10.31.200.1
Domain Name
Name server (DNS) 10.31.200.11
                  208.67.220.220

<F5> Refresh <Page Up/Down> Scroll

```

Some actions may require that you enter a username and password. When prompted, enter the following credentials:

- Username: gridadmin
- Password: xenserver

 Username and Password are case sensitive.

Editing Network Information

1. Use the keyboard arrow keys to navigate to **Configure VCA Networking**.

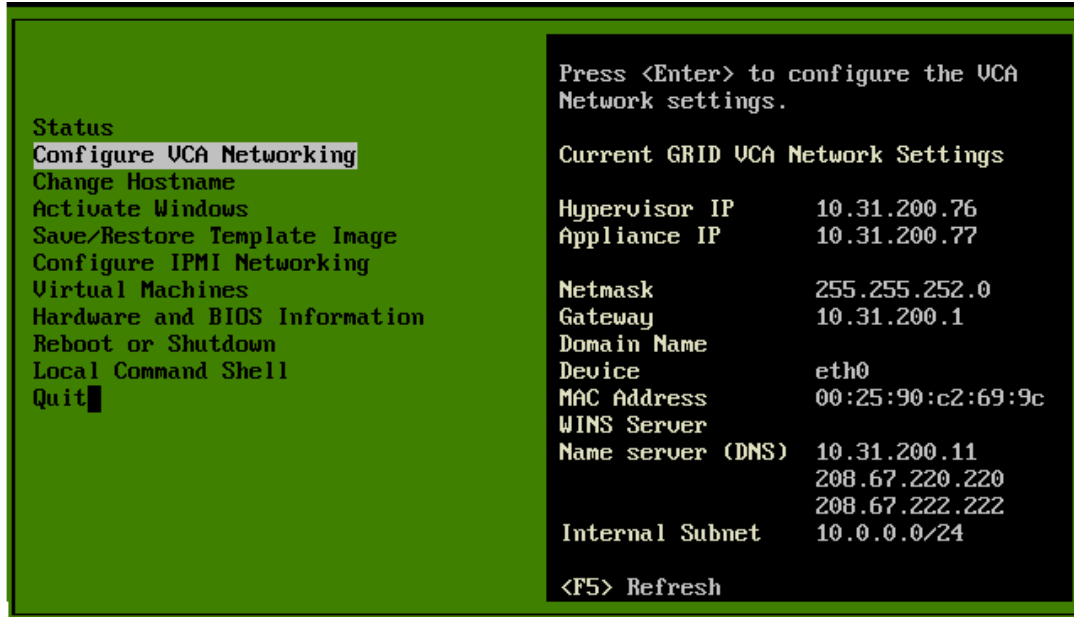

2. Press **<Enter>** to get to the *Configure VCA Networking* screen.

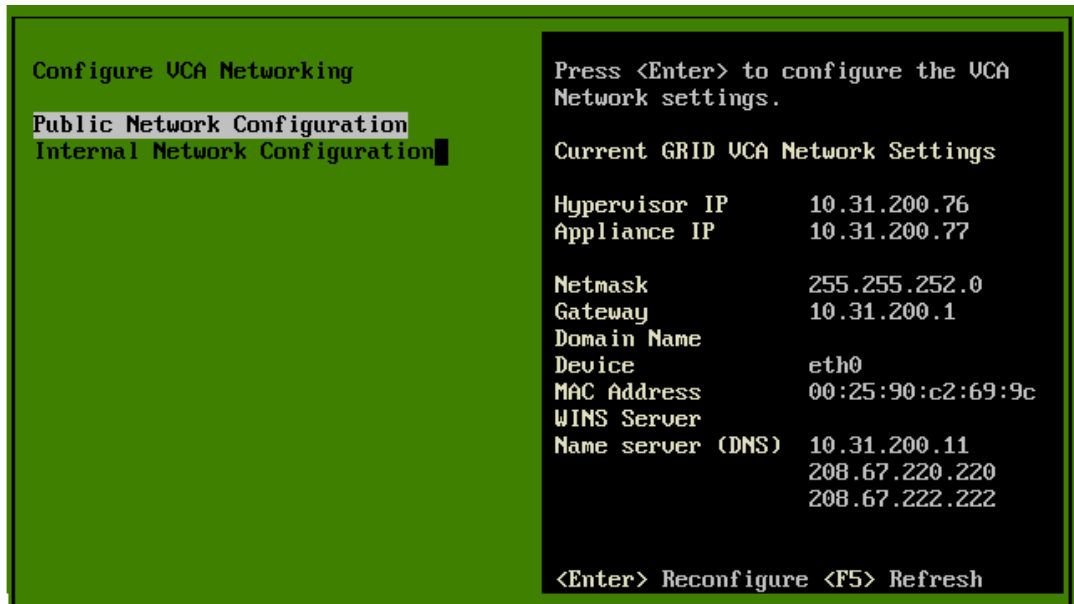

3. Select **Public Network Configuration** and then press **<Enter>**.

The *GRID VCA Network Configuration* prompt appears.

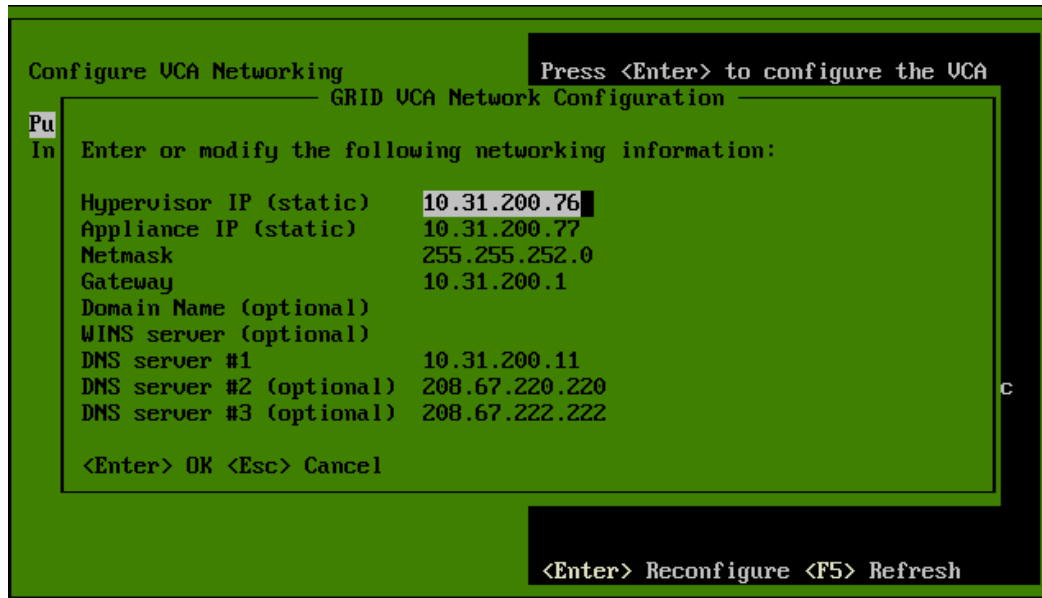

4. Using the keyboard, enter the following information:

- **Hypervisor IP**
- **Appliance IP**
- **Netmask**
- **Gateway**
- **DNS server #1**

The following fields are optional:

Domain Name: Makes it easier to type in the address

WINS server: Needed if a WINS server is used and not added to the DNS

DNS server #2, #3: Used as a backup if DNS server #1 is not available

5. When finished, press **<Enter>**.

The VCA will take a few minutes to configure its networking. When finished, the following message appears.



6. Press **<Enter>** to complete.

Activating Windows

Before activating Windows, you must configure the network information as described in the previous section (see [Editing network information](#)) and verify that the system is on a network that is connected to the internet (in order to access microsoft.com).

1. Use the keyboard arrow keys to navigate to **Activate Windows**.

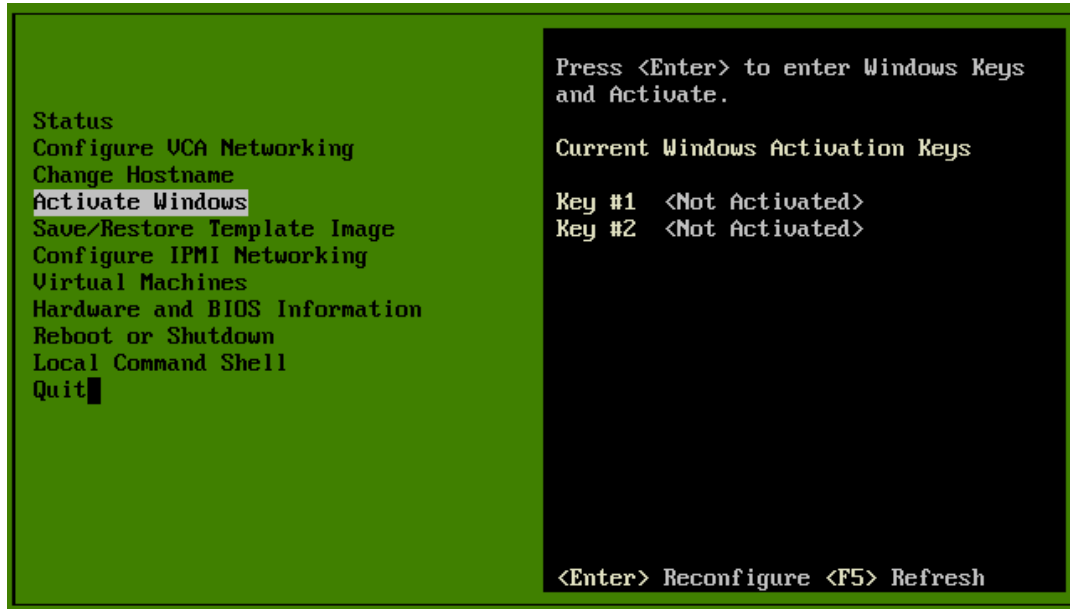

2. Press <Enter>.

The *Current Activation Keys* prompt appears.

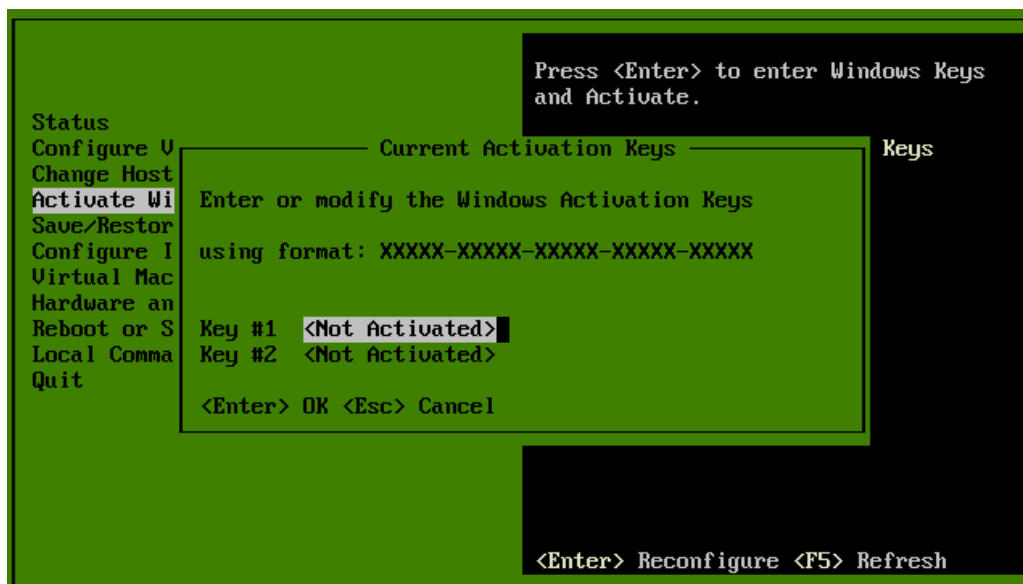

3. Enter the Windows activation keys.

Key #1 and Key #2 information is located on the sticker attached to the GRID VCA.

See [Windows Product Key](#).

The activation script may take several minutes, especially if the system is not already in Maintenance Mode. Activation will take approximately seven minutes, which includes entering Maintenance Mode.

OPTIONAL SETTINGS

This section describes some additional settings and actions that may be needed.

- ▶ [Modifying the Internal Network Addressing Scheme](#)
- ▶ [Configuring an Intelligent Platform Management Interface \(IPMI\)](#)

Modifying the Internal Network Addressing Scheme

The GRID VCA has an internal network for communication between the various virtual machines within the VCA. By default this internal network uses addresses in the range [10.0.0.0 – 10.0.0.255], written as 10.0.0.0/24. Typically there is no need to modify this setting. However in special circumstances it may be desirable to have the VCA use a different internal network addressing scheme.

To change the internal network addressing, do the following:

1. From the Setup Console main page, navigate to **Configure VCA Networking** and then press **<Enter>** to get to the *Configure VCA Networking* screen.

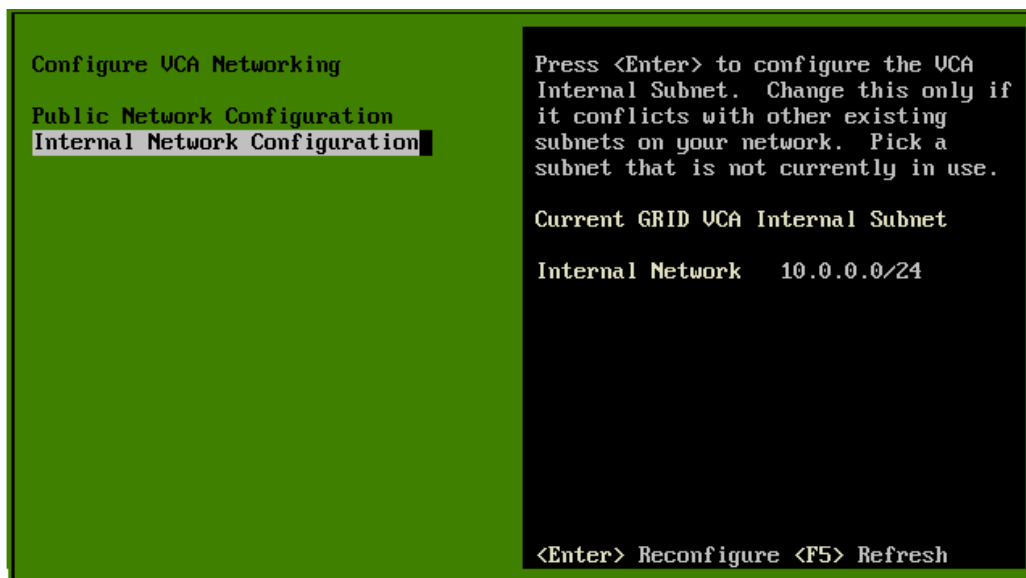

2. Select **Internal Network Configuration** and then press **<Enter>**.

The *Configure Internal Network* prompt appears.

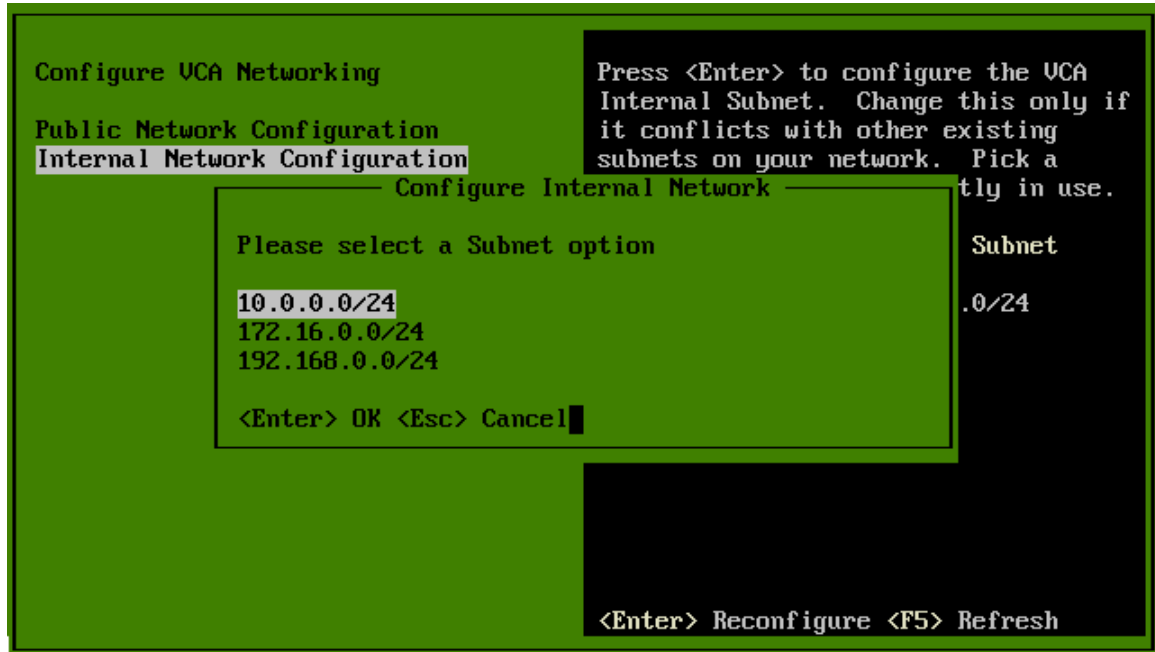

3. Select one of the Subnet options, then press **<Enter>**.

The VCA begins the process of setting up the new internal network addressing. This takes a few minutes to complete.

Configuring an Intelligent Platform Management Interface (IPMI)

To configure IPMI networking for remote console capability, do the following:

1. Connect a network cable to the IPMI LAN port on the back of the system.

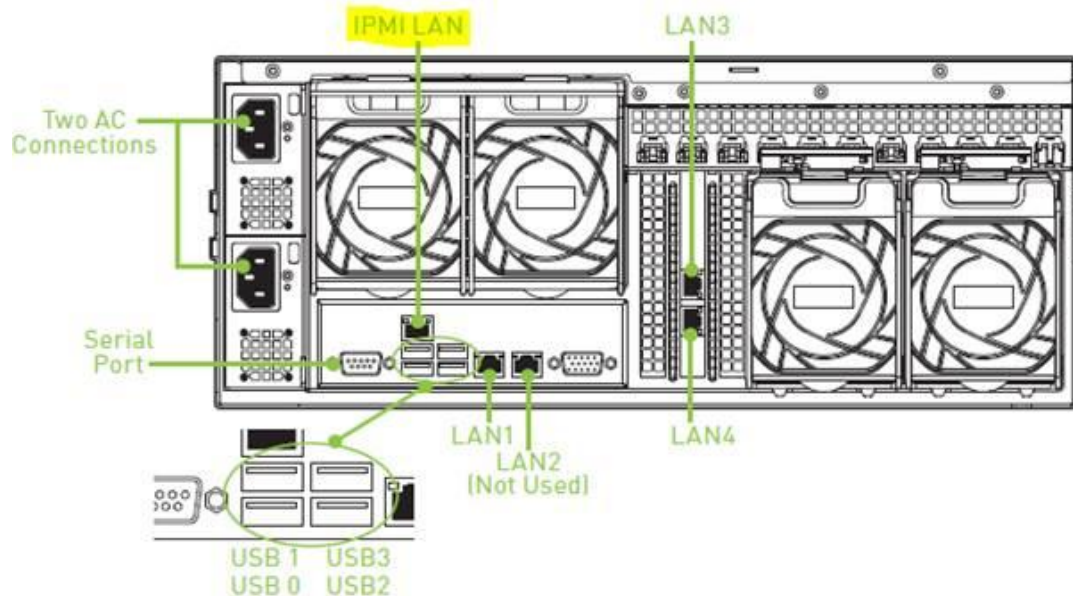

2. From the Setup Console main page, navigate to **Configure IPMI Networking**.

```

Status
Configure VCA Networking
Change Hostname
Activate Windows
Save/Restore Template Image
Configure IPMI Networking
Virtual Machines
Hardware and BIOS Information
Reboot or Shutdown
Local Command Shell
Quit

Press <Enter> to configure the IPMI
Network settings.

Current GRID IPMI Network Settings

NOTE: A network cable must be
connected to the IPMI NIC. A missing
cable cannot be detected by this
interface.

IP Address      10.31.200.102
Netmask        255.255.252.0
Gateway        10.31.200.1

<Enter> Reconfigure <F5> Refresh

```

3. Press <Enter>.

The DHCP/Static selection dialog appears.

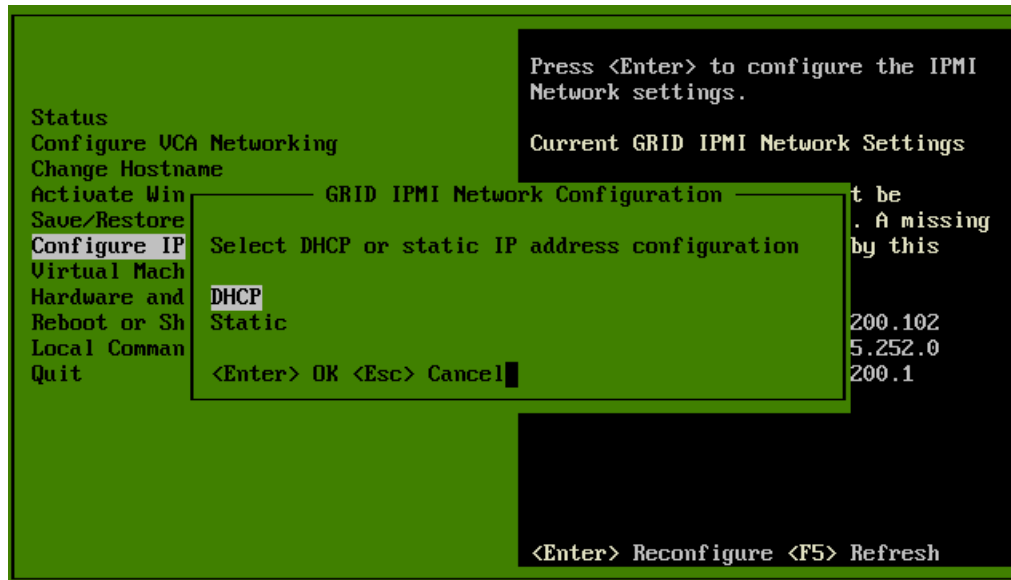

4. Select **DHCP** or **Static**, depending on the addressing that you want to configure, then press <Enter>.

Static Addressing

If you selected **Static**, then the following screen appears where you can specify the IP, Netmask, and Gateway addresses.

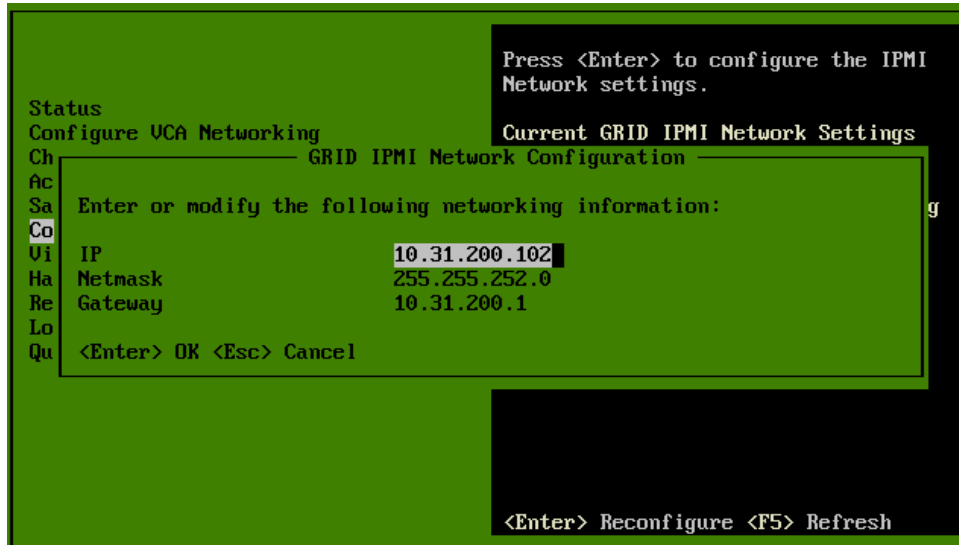

1. Press **<Enter>** if you accept the default address for each row, or enter a specific address and then press **<Enter>** to proceed to the next row.

The final Static address screen appears showing your configuration.

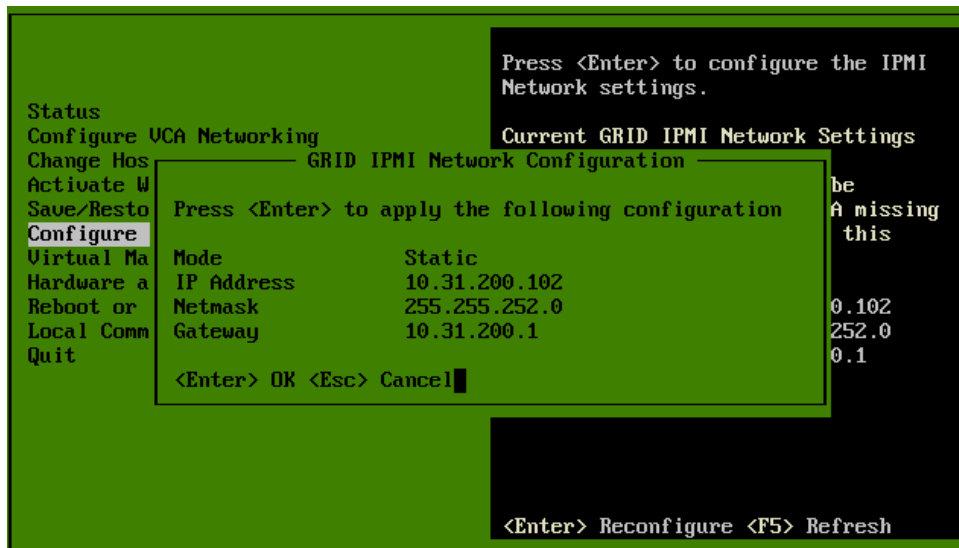

2. Press **<Enter>** to apply the static configuration

DHCP Addressing

If you selected **DHCP**, the following screen appears showing the DHCP addressing:



Press **<Enter>** to apply the DHCP configuration.

Connecting to the IP Address

After setting up the network, you can connect to this IP address, but must use Internet Explorer, with Java 7 installed.

1. Enter the IP address as the URL.

The Login screen appears.

2. At the Login screen, enter the following credentials, then click **Login**:
 username: **ADMIN**
 password: **ADMIN**

- Once logged in, you can access the remote console by selecting **Remote Control** -> **Console Redirection**:

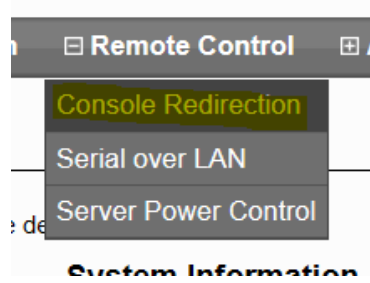

- Click **Java Console** to access the VCA remotely.

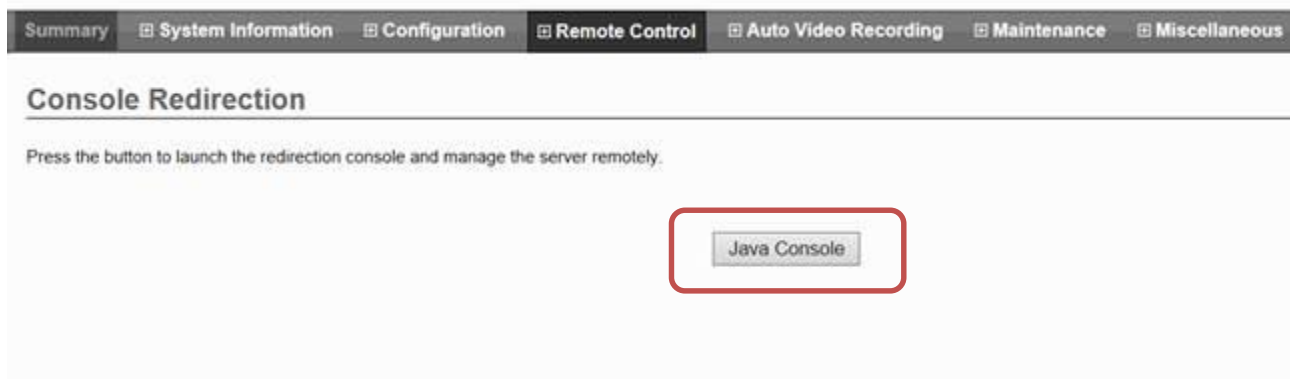

The VCA Setup Console appears in the viewer.

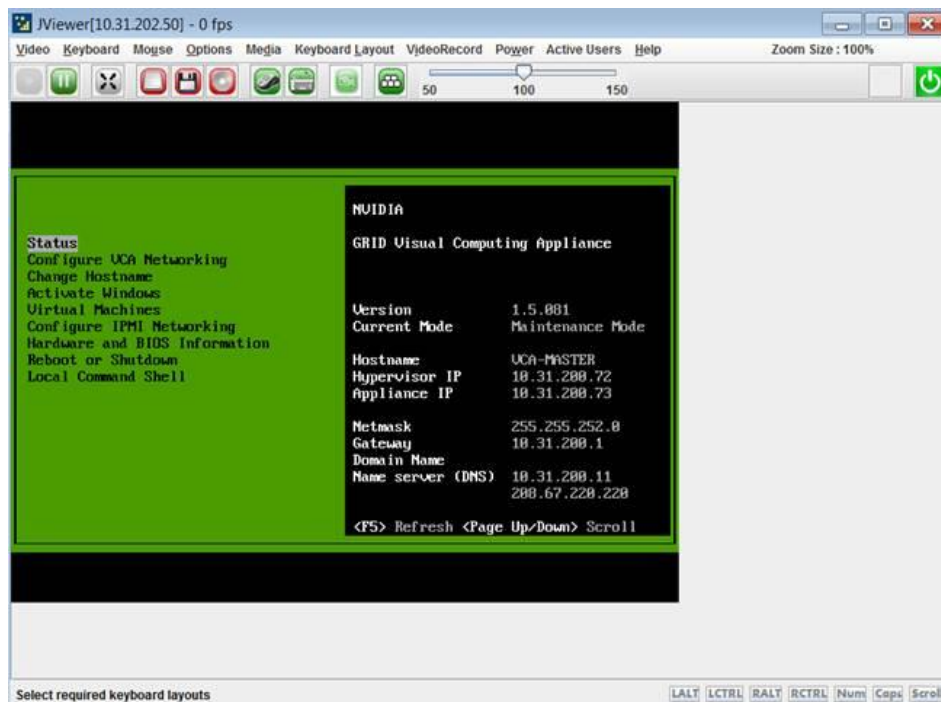

Exporting and Importing the Template

After a GRID template is created, administrators can back it up (export) to either an NFS server or to a USB device connected to the GRID VCA. Once backed up, the template can then be restored (imported). Administrators can use the Setup Console to accomplish either task.



Note: The template image can be very large, depending on the applications installed and other changes made to the desktop. Consequently, the export and import process takes some time. For example, the export process takes about two hours.

During the export or import process, the VCA cannot be used for any other activity.

Using an NFS Server

The NFS server must allow the GRID VCA to use the Linux *mount* command to mount the directory without requiring user credentials.

Using a USB Device

The Setup Console will display all available disk partitions on all USB devices connected to the GRID VCA.

When saving to a USB device, it is easiest to have only one USB device plugged into the GRID VCA, otherwise you will need to know the device name of each in order to specify where to save the backup template.

How to Export the Template Image

1. Open the Setup Console and navigate to **Export or Import Template Image**.

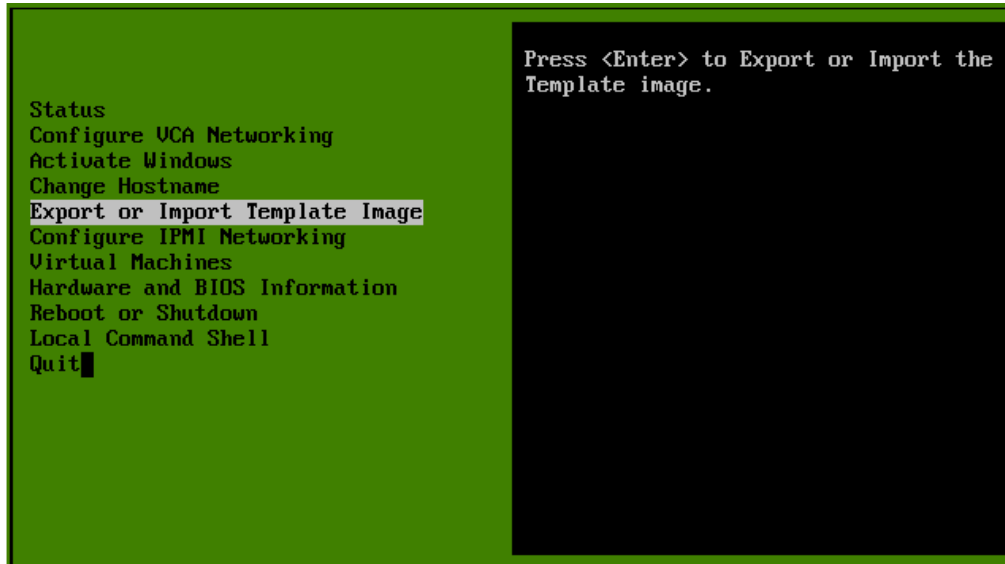

2. Press <Enter>.



3. Select **Explore Template** and press <Enter>.

The *Where to Export Template Image* popup appears.

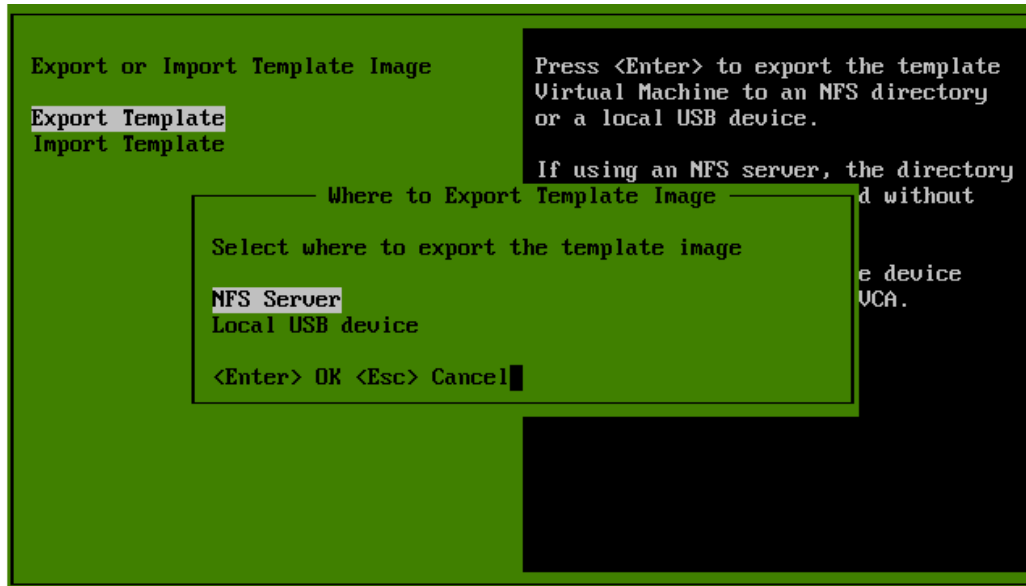

Note: The *Local USB device* option appears only if a USB device is plugged into the GRID VCA.

4. Select where to export the template image and then press **<Enter>**.
 - If you selected **NFS Server**, then after pressing **<Enter>**, enter the IP address of the server and the directory where you want the template stored, then press **<Enter>**.



- If you selected **Local USB device**, then enter the USB disk partition where to export the template image, then press **<Enter>**.



How to Import the Template

1. Open the Setup Console and navigate to **Export or Import Template Image**.

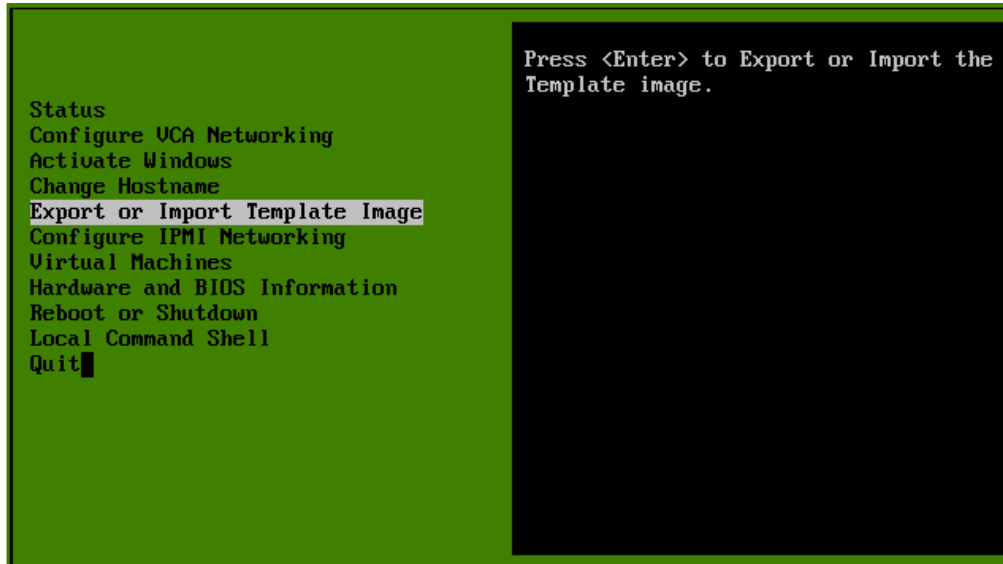

2. Press <Enter>.



3. Select **Import Template**, and then press <Enter>.
The *Where to Import Template Image From* popup appears.

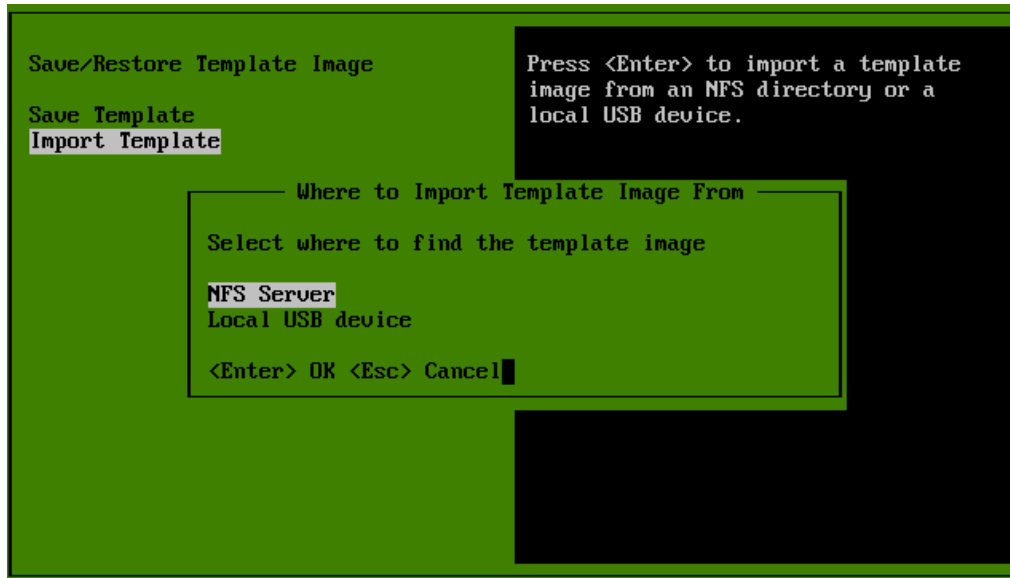

Note: The Local USB device option appears only if a USB drive is plugged into the GRID VCA

4. Select where to find the template image and press <Enter>.
 - If you selected **NFS Server**, then enter the IP address of the server and the directory from where to import the template, and press <Enter>.

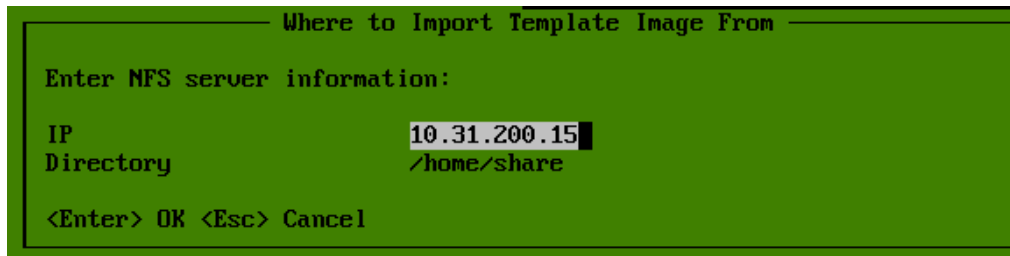

- If you selected **Local USB device**, then enter the USB disk partition from where to import the template, and press <Enter>.



INSTALLING THE GRID WORKSPACE CLIENT

This document describes how to install the NVIDIA GRID Workspace Client software Version 1.5 (1.5.xx).

SYSTEM REQUIREMENTS

Operating System

The NVIDIA GRID Workspace client software is designed to work with the following operating systems:

- ▶ Windows XP or later, 32-bit or 64-bit
- ▶ Mac OSX 10.6 or later
- ▶ Linux Ubuntu 12.04 LTS
- ▶ Red Hat Enterprise Linux version 6



Note: You must have administrator or root privileges to install the GRID Workspace Client Application.

Hardware

The basic requirements for working in 1280 x 720 at 60 frames-per-second or 1920 x 1080 at 30 frames-per-second are:

- ▶ Intel® Core™ Duo or later processor, 1.8 GHz minimum
- ▶ HDD space: 70 MB minimum
- ▶ RAM: 1 GB minimum, 2 GB recommended
- ▶ Ethernet: Minimum 5 Mbps-capable connection; 10 Mbps recommended

The additional requirements for working in 1920 x 1200 at 60 frames-per-second are:

- ▶ 18 Mbps-capable Ethernet connection, plus one of the following
- ▶ NVIDIA Kepler-class graphics card (for hardware accelerated H.264 decoding¹)
or
- ▶ Intel Core i5 or later processor

¹ Hardware accelerated H.264 decoding on the client system provides the best low latency experience especially when working in higher resolutions and frame rates.

END USER LICENSE AGREEMENT

The End User License Agreement must be accepted before a Workspace client can connect to the GRID VCA Appliance. You can view and accept the EULA by doing the following:

1. Using the Web browser, type: `https://<GRID Appliance IP>:444`
(for example `https://192.168.1.5:444`)
2. Enter the following username and password on the login screen
 - Username: admin
 - Password: test

Username and Password are case sensitive.

3. Select **Accept** at the bottom of the Web page.

Once the agreement is accepted, you can proceed to connect a Workspace client to the GRID VCA.



Note: After you have accepted the EULA you can always review it by entering the following IP in your browser: `https://<GRID Appliance IP>:444/eula`

INSTALLATION INSTRUCTIONS

The following sections describe the installation of the GRID Workspace client application for the supported operating systems.

- ▶ [Microsoft Windows](#)
- ▶ [Linux](#)
- ▶ [Apple Mac OS](#)



Note: You must have administrator or root privileges to install the GRID Workspace Client Application.

Microsoft Windows

The GRID Workspace Client Application will run only on the following Windows client systems:

- ▶ Windows XP (32-bit and 64-bit)
- ▶ Windows 7 (32-bit and 64-bit)
- ▶ Windows 8 (32-bit and 64-bit)

Installation and Setup

1. Using a Web browser, download the software from the GRID VCA.



Note: GRID VCA has been tested with, and supports, Google Chrome Web browser.

- a) Type `http://<GRID Appliance IP>` (for example, <http://192.168.1.5>) into the address bar of your web browser.

The NVIDIA GRID VCA Set Up page appears.



- b) Click Set up for Windows.

2. Run the downloaded file (*GRID Workspace-Win.exe*) and follow the instructions to install the GRID Workspace client application on your system.



Note: You must accept the software license agreement during installation. The installer will perform a system check before installing the GRID Workspace Client, and indicate when the installation is finished.

3. Once the installation is complete, click **Close**.

Opening the GRID CLIENT Workspace

If you selected **Launch NVIDIA GRID Workspace** during installation, then the GRID Workspace launches when you click **Close**. Otherwise, from the Windows Start button, click All Programs->NVIDIA Corporation->NVIDIA GRID Workspace.



Opening the GRID CLIENT Workspace the First Time

If you open the GRID Client Workspace for the first time after an initial installation, the *Help Improve GRID VCA* dialog appears where you can choose whether or not you want the GRID Client to send analytic data to NVIDIA.

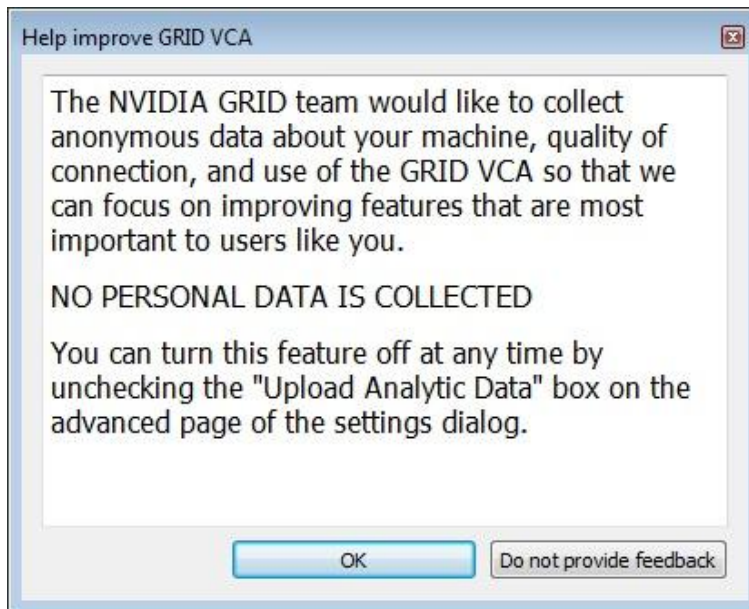

After clicking either **OK** or **Do not provide feedback**, the *GRID VCA Connection Settings* dialog opens.

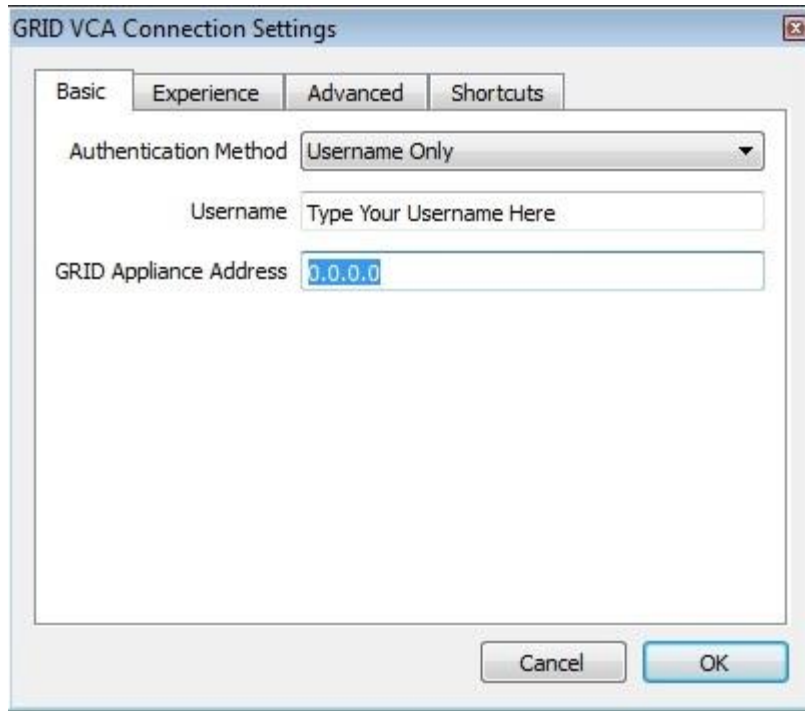

1. On the **Basic** tab and enter the following information:
 - Authentication Method (verify that Username Only is selected)
 - Username (user-defined name to identify user in a Web-based management interface)
 - GRID Appliance Address (the GRID Appliance IP Address)
2. Click the **Advanced** tab.

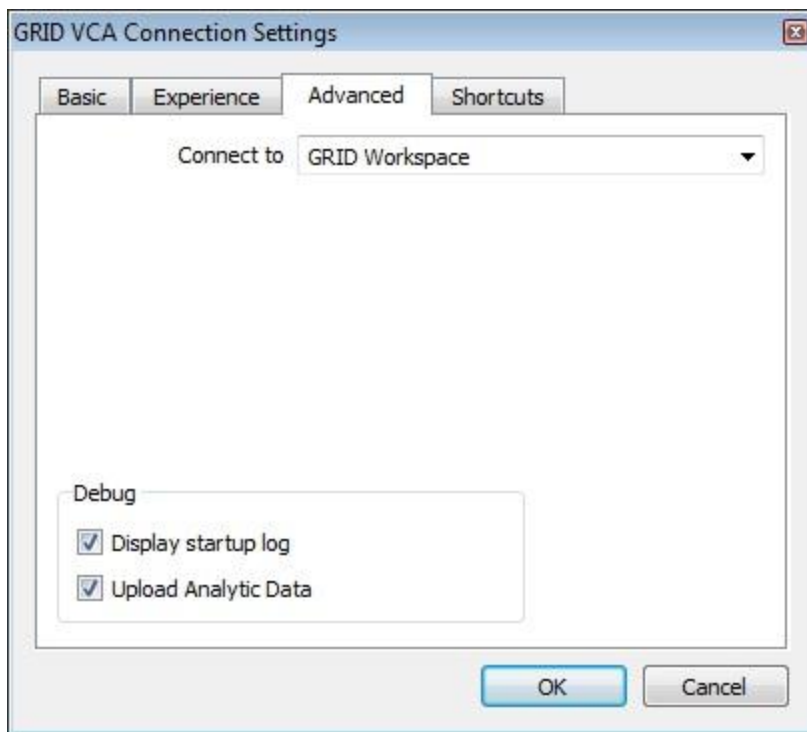

3. Set the **Connect to** drop-down box to " GRID Workspace."
4. Click **OK** to accept these settings.

The GRID Workspace opens on your desktop.

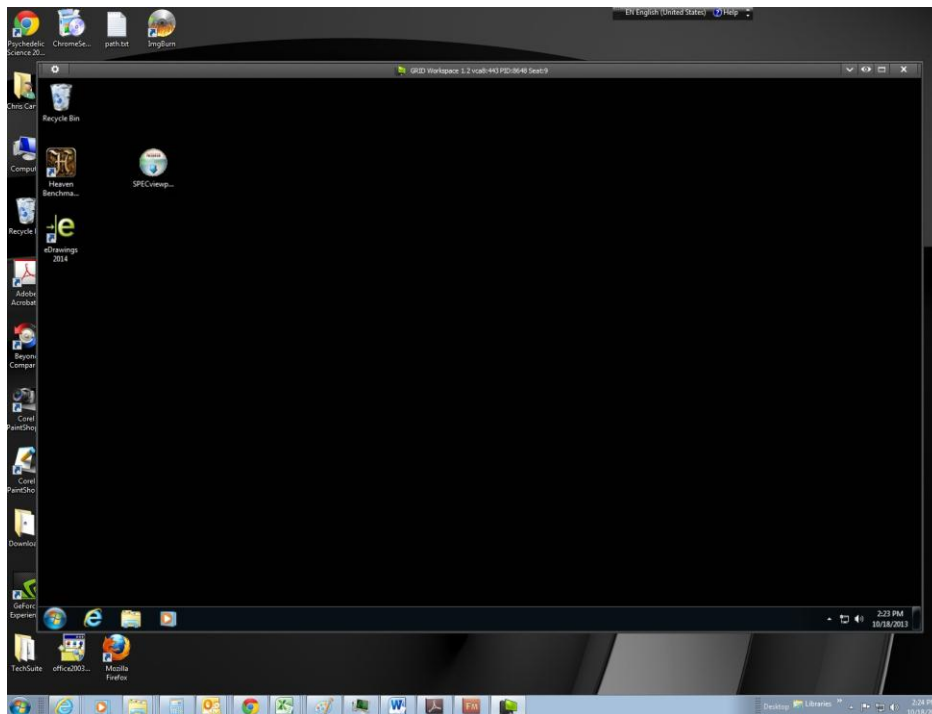

Linux

The GRID Workspace Client Application will run only on the following Linux client systems:

- ▶ Linux Ubuntu 12.04 LTS (32-bit)
- ▶ Linux Ubuntu 12.04 LTS (64-bit)
- ▶ Red Hat Enterprise Linux version 6 (desktop and workstation)

Installation and Setup

1. Using a Web browser, download the software from the GRID VCA.
 - a) Type `http://<GRID Appliance IP>` (for example, <http://192.168.1.5>). The NVIDIA GRID VCA Set Up page appears.



- b) Click **Linux**.
2. Save the Workspace Client to a known location on the client system.



3. Extract the .tgz package to a desired location on the system.

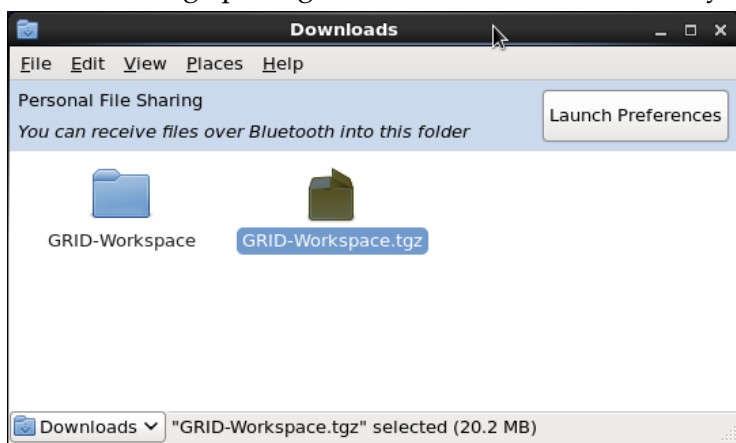

Opening the GRID Client Workspace

Run the **GRID Workspace binary**, located in the directory where the GRID Workspace client package was extracted.

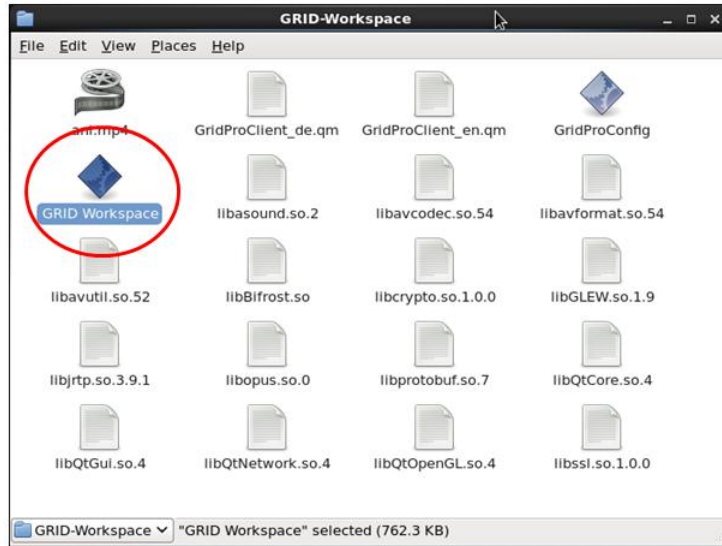

Opening the GRID CLIENT Workspace the First Time

If you open the GRID Client Workspace for the first time after an initial installation, the *Help Improve GRID VCA* dialog appears where you can choose whether or not you want the GRID Client to send analytic data to NVIDIA.

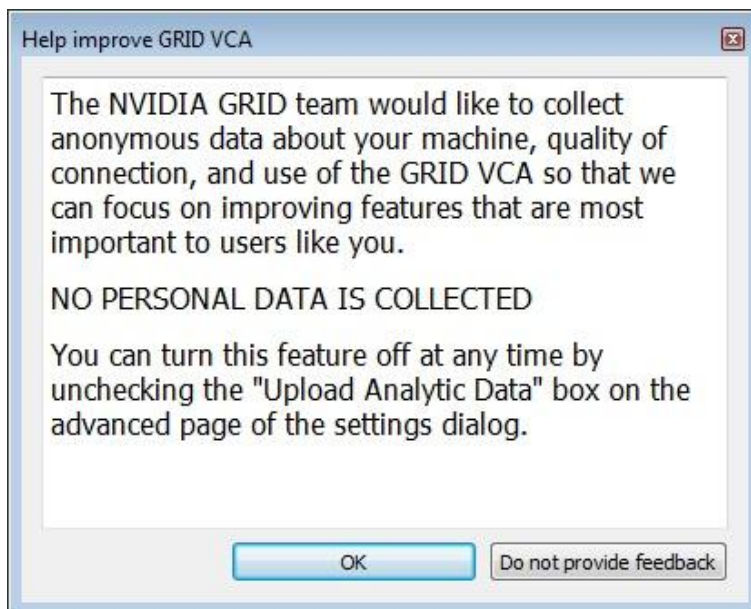

After clicking either **OK** or **Do not provide feedback**, the *GRID VCA Connection Settings* dialog opens

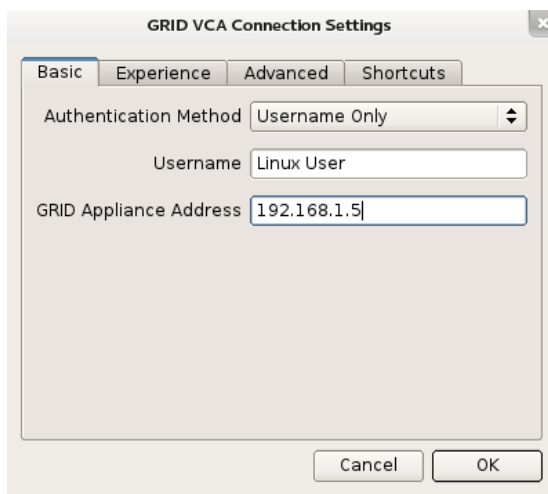

1. Enter the following information under the **Basic** tab:
 - Authentication Method (verify that **Username Only** is selected)
 - User (user-defined name to identify user in a Web-based management interface)
 - GRID Appliance Address (the GRID Appliance IP Address)

2. Click the **Advanced** tab.

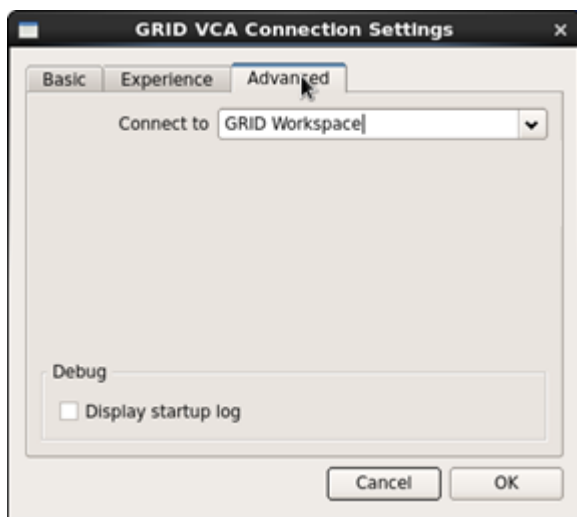

3. Set the **Connect to** drop-down box to "GRID Workspace."
4. Click **OK** to accept these settings.

The GRID Workspace Client will start and display the GRID Workspace.

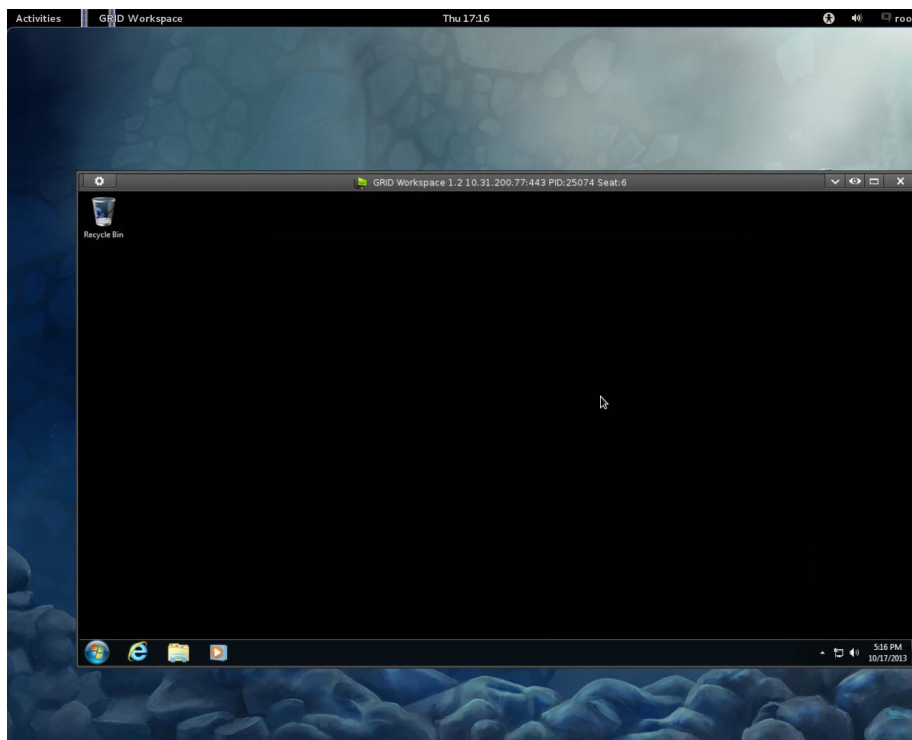

Apple Mac OS

The GRID Workspace Client Application will only run on the following Apple Mac client systems:

- ▶ Mac OSX (10.6 “Snow Leopard”)
- ▶ Mac OSX (10.7 “Lion”)
- ▶ Mac OSX (10.8 “Mountain Lion”)

Installation and Setup

1. Using a Web browser, download the software from the GRID VCA.
 - a) Type `http://<GRID Appliance IP>` (for example, <http://192.168.1.5>).
The NVIDIA GRID VCA Set Up page appears.



- b) Click **Mac OS**.

2. Save the Workspace Client to a known location on the client system.

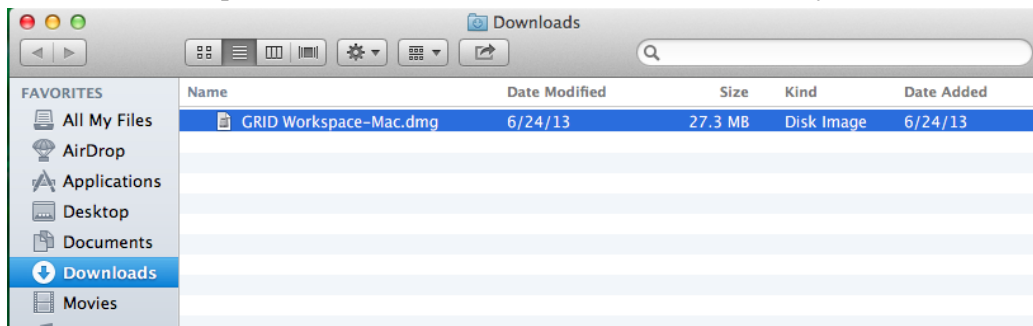

Opening the GRID Client Workspace

1. Return to the application folder where the GRID Workspace Client was installed and start the GRID Workspace Client.



To bypass Gatekeeper for this application and allow it to run on this system,

- a) Right-click the *GRID Workspace* icon to open the context menu.
- b) Press [control] + select **Open** from the context menu.

The following message appears:

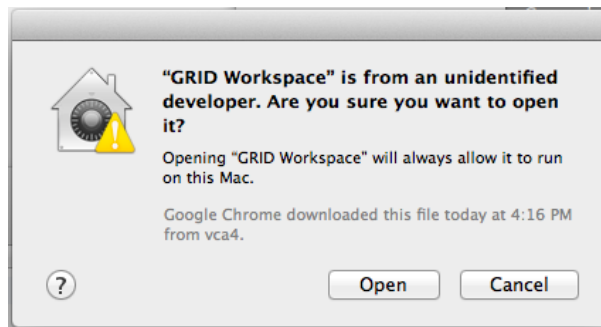

- c) Click **Open**.

Opening the GRID CLIENT Workspace the First Time

If you open the GRID Client Workspace for the first time after an initial installation, the *Help Improve GRID VCA* dialog appears where you can choose whether or not you want the GRID Client to send analytic data to NVIDIA.

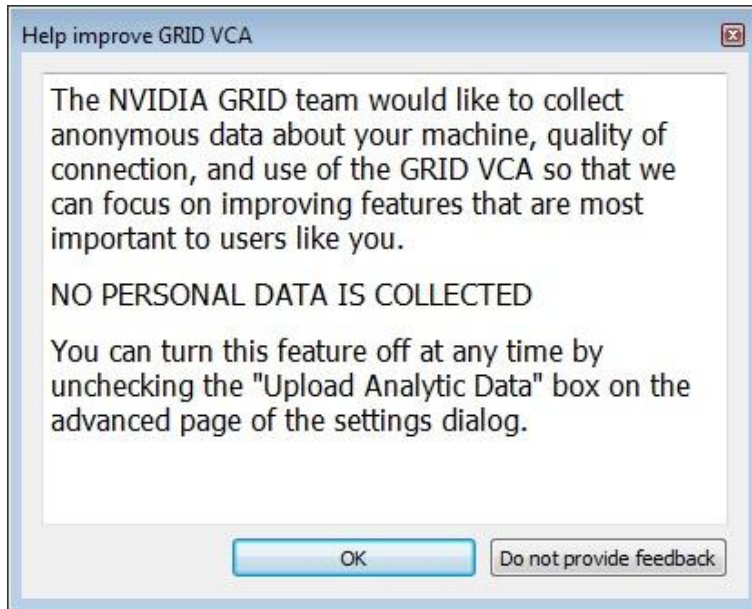

After clicking either **OK** or **Do not provide feedback**, the *GRID VCA Connection Settings* dialog opens

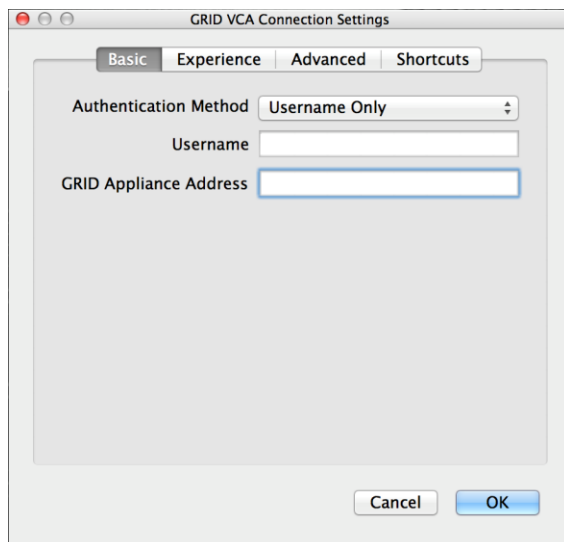

1. Enter the following information under the **Basic** tab:
 - Authentication Method (verify that Username Only is selected)
 - User (user-defined name to identify user in a Web-based management interface)
 - GRID Appliance Address (the GRID Appliance IP Address)

2. Click the **Advanced** tab.

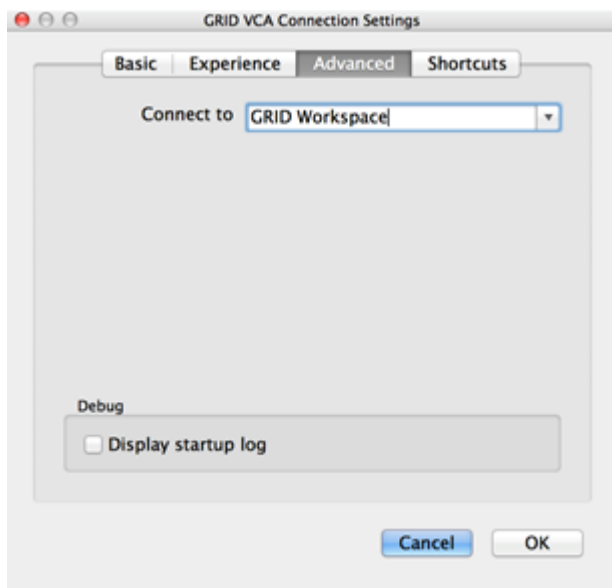

3. Set **the Connect to** drop-down box to "GRID Workspace."
4. Check that the default port of "443" is entered in the GRID Appliance Port box.
5. Click **OK** to accept these settings.

The GRID Workspace Client will start and display the GRID Workspace.

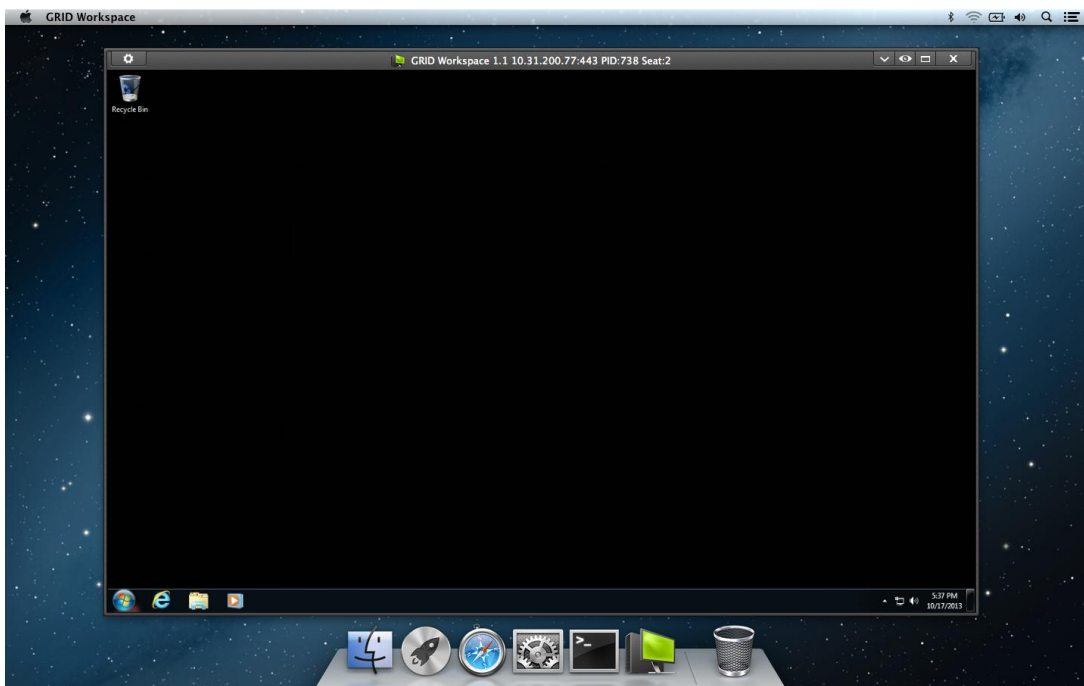

USING THE GRID WORKSPACE CLIENT

OPENING THE GRID WORKSPACE

The location of the GRID Workspace application depends on the operating system. Please refer to the previous GRID Workspace Installation sections for instructions on installing the application on your operating system.

Default Install location

Windows	From the Windows Start button, click All Programs->NVIDIA Corporation->NVIDIA GRID Workspace .
Linux	Run the GRID Workspace binary , located in the directory where the GRID Workspace client package was extracted.
Mac OS	Run the GRID Workspace Client , using Launchpad or directly from the application folder.



Note: The GRID Workspace Connection Settings dialog opens automatically the first time you launch **GRID Workspace** on your Windows, Linux, or Mac system. If you had a previous version of the client already installed, the **Connection Settings** dialog will not open automatically, and the previous settings will be used.



Note for Notebooks: In order to conserve energy when running on battery power, some notebooks limit CPU power. This can result in a performance drop when running the GRID VCA Client. To ensure that you get the best performance when using the GRID Workspace, use AC power.

CLOSING THE GRID WORKSPACE

To close the GRID Workspace,

1. Click the close button  on the title bar, or alternately, click the configuration icon  and then select **Quit**.

The Release/Preserve dialog appears.

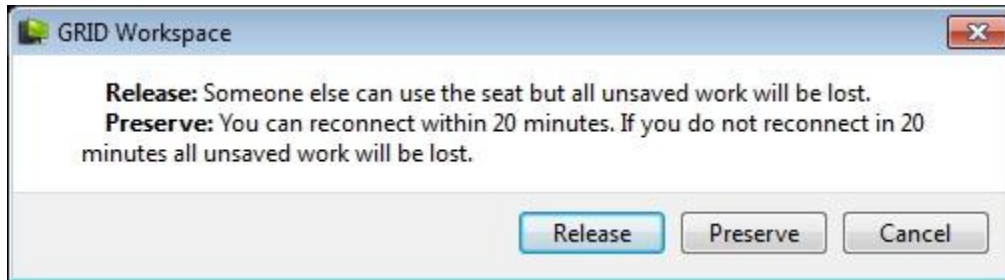

2. Click **Release** or **Preserve**, depending on whether you plan to reconnect within 20 minutes.



Do not attempt to close the GRID Workspace by logging out of Windows or shutting down Windows within the workspace.

NAVIGATING THE GRID WORKSPACE

The workspace opens in a window on your desktop.

Working with the Workspace

You can reposition the window and resize it as needed.

- ▶ To reposition the window, place the mouse on the title bar so that the cursor turns into this icon , then click and drag.
- ▶ To resize the window, place your mouse anywhere on the window frame so that it turns into this double arrow icon , then click and drag in the direction of the arrows.

The window maintains its proportions as it resizes.

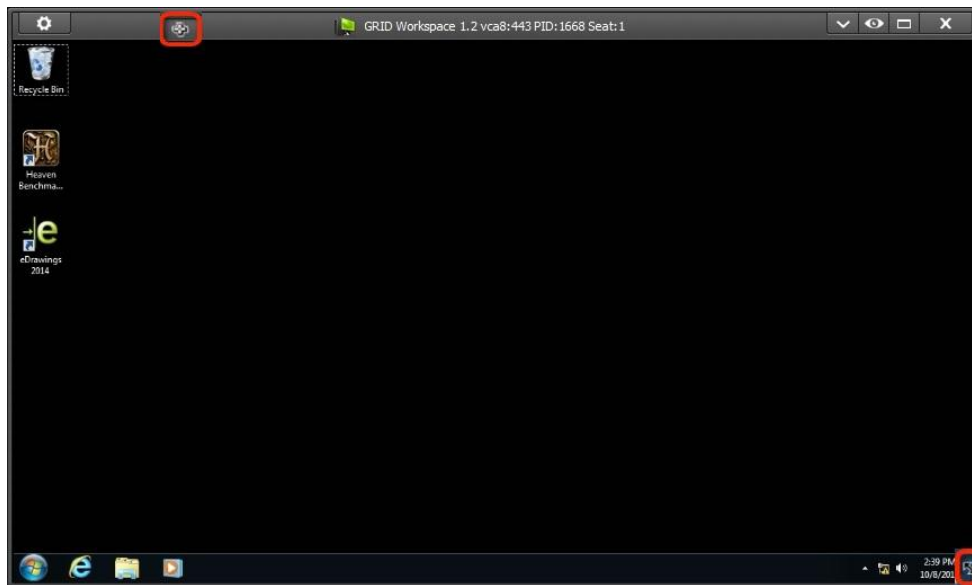

Note: Resizing the window will scale the pixels, which could result in a blurry image. For the best quality full screen image match the screen resolution setting in the experience tab with your local computers screen resolution or press the  button to scale the window to match the streaming resolution.

If you want to change the actual screen resolution, use the GRID VCA Connection Settings controls (see [Configuring GRID Client Settings](#)). Remember to close and then reopen the GRID Workspace for the changes to go into effect.

See [Window Controls](#) for a description of other controls you can use to manipulate the workspace window.

The Title Bar

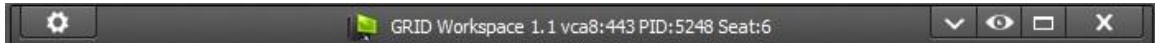

The GRID Workspace title bar has several controls that let you customize your experience.

Configuration Icon



This is the configuration icon.

Clicking on the configuration icon opens a drop down menu.



- ▶ **Show Settings Dialog:** Opens the GRID VCA Connections dialog. See [Configuring GRID Client Settings](#).
- ▶ **Display in Full Screen:** Select to toggle the workspace in and out of full-screen mode. To exit full-screen mode, use the hot keys (Windows/Linux: Ctrl + Shift + F) (Mac: Command + Shift + F), or use the auto-hide title bar.

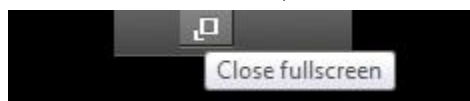

- ▶ **Use Local Mouse:** Enable this setting to minimize perceived latency and response time. When enabled the mouse cursor is drawn using your local client machine instead of being drawn remotely and delivered with the streaming desktop.

Note: This setting does not change the actual latency or response time. It only impacts the perceived latency for most operations².

² Perceived latency is subjective because even the same application can "feel" different depending on the content; for example, different model sizes, specific operating modes, and screen resolution. The local mouse

- ▶ **Show FPS Indicator:** Toggle this setting to display or hide the frames per second graph. When enabled, a FPS graph similar to the image below is displayed at the bottom right hand corner of the GRID Workspace client.

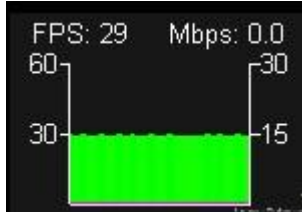

The indicator also shows the streaming bit rate in megabits per second (Mbps).

- ▶ **Save Screenshot:** Click to take a screen capture of the workspace and save as a JPEG.
Hint: The same folder is used to store the log files, so to quickly open the folder, select **Open Logs**, which opens the folder directly.
- ▶ **Start Recording Video:** Click to start recording the activity in the Workspace, then click **Stop Recording Video** to stop the recording. An H.264 formatted video is created and stored in the logs folder.
Hint: To quickly open the folder, select **Open Logs**.
- ▶ **Open Logs:** Click to open the folder that contains the log files.
These logs contain information about the client configuration as well as all popups and messages that occur during a session. The information helps engineering root cause issues such as slowness and disconnection.
- ▶ **About:** Opens the *About* dialog, similar to the one below, which displays the version of the GRID Workspace Client software.

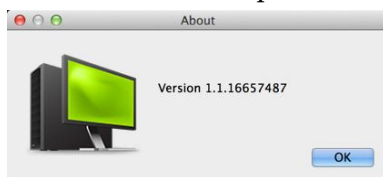





- ▶ **Quit:** Closes the GRID workspace.

setting changes the feel for some interactions such as menu picking but not for others such as object positioning. This setting is selectable by the user because the user will evaluate the experience and choose between a locally rendered mouse or a remotely rendered mouse.

Window Controls



The window controls let you minimize, maximize, and resize the GRID Workspace window.

- ▶ Click this button  to minimize the GRID Workspace window.
- ▶ Click this button  to maximize the GRID Workspace window; clicking this button  restores the window to the size it was before you maximized it.
- ▶ Click this button  to resize the GRID Workspace window so that it matches the streaming window resolution. This will deliver the sharpest view because the streamed pixels will not be resized.
- ▶ Click this button  to close the GRID Workspace.



Note: If you want to change the actual screen resolution, use the GRID VCA Connection Settings controls (see [Configuring GRID Client Settings](#)). Remember to close and then reopen the GRID Workspace for the changes to go into effect.

CONFIGURING GRID CLIENT SETTINGS

The GRID Workspace Client offers several user experience options. These options may be adjusted depending on the target workflow or required level of experience for a particular user. User experience adjustments include screen resolution, bit rate, and frame rate, among others. The section discusses several of these user experience options and describes their effect on the VCA system and network.



Note: For any changes to take effect, you must close and then reopen the GRID Workspace.

You can open the GRID VCA Connection Settings window through the GRID Workspace.

1. Open the GRID Workspace, then click the gear icon at the upper left corner.
2. From the dropdown menu, click **Show Settings Dialog**.



The *GRID VCA Connection Settings* window opens.

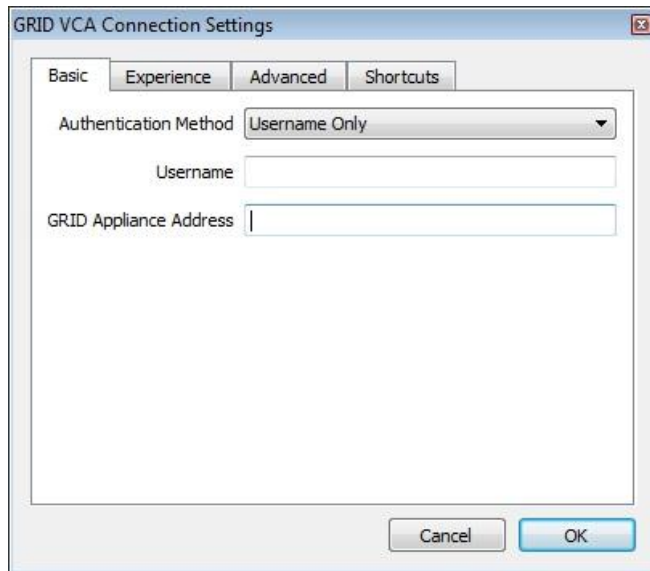

- ▶ The **Basic** and **Advanced** tabs are used for network and connectivity settings. The Advanced tab should already be filled with the information used to connect to the GRID VCA.
- ▶ The **Experience** tab has the screen resolution, bit rate, and frame rate settings for the GRID Workspace.
- ▶ The **Shortcuts** tab lets you define your own keyboard shortcuts for the GRID Workspace client application.

See the rest of this section for a detailed description of each tab.

Basic Tab

The *Basic* tab lets you enter the basic information needed to connect to the GRID VCA.

The screenshot shows a dialog box titled "GRID VCA Connection Settings" with four tabs: "Basic", "Experience", "Advanced", and "Shortcuts". The "Basic" tab is selected. It contains the following fields:

- Authentication Method:** A dropdown menu currently set to "Username Only".
- Username:** An empty text input field.
- GRID Appliance Address:** An empty text input field.

At the bottom of the dialog box are two buttons: "Cancel" and "OK".

► **Authentication Method:**

- **Username Only:** Select this option if you can access the GRID VCA with only a username.
- **Active Directory:** Select this option if you need a username and password to access the GRID VCA.

► **Username:** User-defined name to identify the user on the Operator Console

► **GRID Appliance Address:** GRID Appliance IP Address

Experience Tab

The *Experience* tab lets you configure various display settings of the workspace.

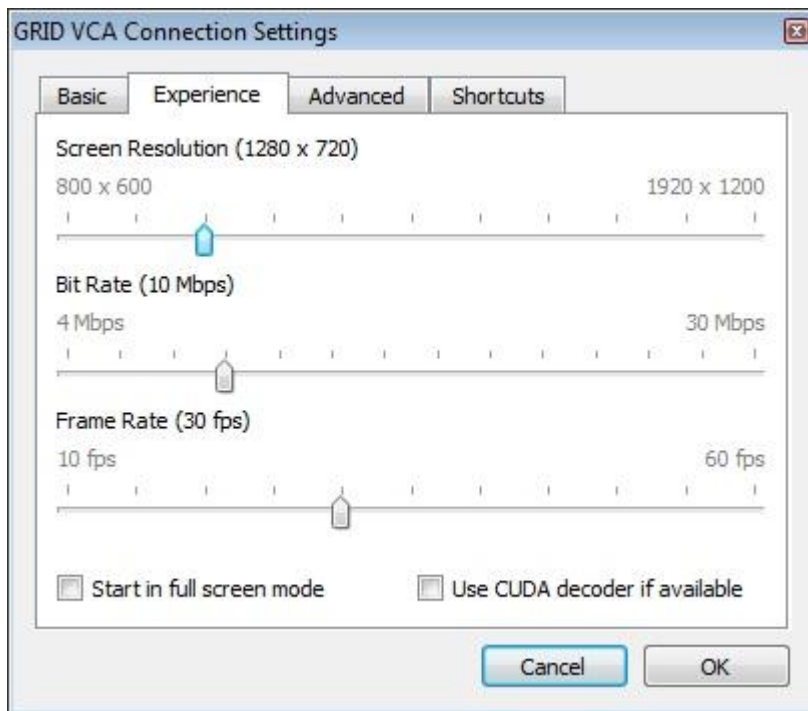

- ▶ **Screen Resolution:** This setting adjusts the size of the workspace in horizontal and vertical pixels. The maximum workspace resolution is 1920 × 1200.



Note: It is recommended you set this resolution to the same resolution (or smaller) as the physical client display.

- ▶ **Bit Rate:** This setting adjusts the streaming bit rate, in megabits-per-second. A lower bit rate consumes fewer network resources, but may not deliver a clear image. Conversely, a higher bit rate consumes more network resources, but provides a clearer image. This setting should be adjusted based on your workflow needs. A higher bit rate is recommended for higher resolutions and frame rates.

- ▶ **Frame Rate:** The VCA updates the entire workspace window using a sequence of “frames”, measured in frames per second (FPS). The frame rate setting affects how quickly the window is updated. The default setting is 30 frames per second (FPS), which works for most applications. Higher frame rates are typically desirable when an application makes continuous and highly frequent changes to the screen. A high frame rate setting may not provide any advantage if the application being viewed is not updating at the same rate. Thus, the frame rate setting should be adjusted with knowledge of the desired application(s) and workflow.



Note: Due to hardware limitations and depending on the resolution, the actual frame rate may be less than the selected frame rate if set to 60 fps.

- ▶ **Start in full screen mode:** When checked, the GRID Workspace client starts at full screen instead of in a window.
- ▶ **Use CUDA decoder if available:** (Windows only) The VCA delivers an encoded stream of visual data to the GRID Workspace client. When this setting is checked, the GRID Workspace client attempts to use CUDA to decode the stream. If you have a CUDA-enabled GPU in your client device, this setting delivers higher performance. On client devices without a CUDA decoder, the client incurs a higher CPU load.



Note: If you recently closed a session and chose to preserve the settings, then the resolution, bit rate, and frame rate will switch to those previous settings once a seat is assigned upon opening a new session. (This occurs only if a new session is opened within the session disconnect timeout period. See the [Configuration](#) section for information on setting the “session disconnect” timeout.)

Advanced Tab

The *Advanced* tab is for entering the following connection settings to use when connecting to the GRID VCA.

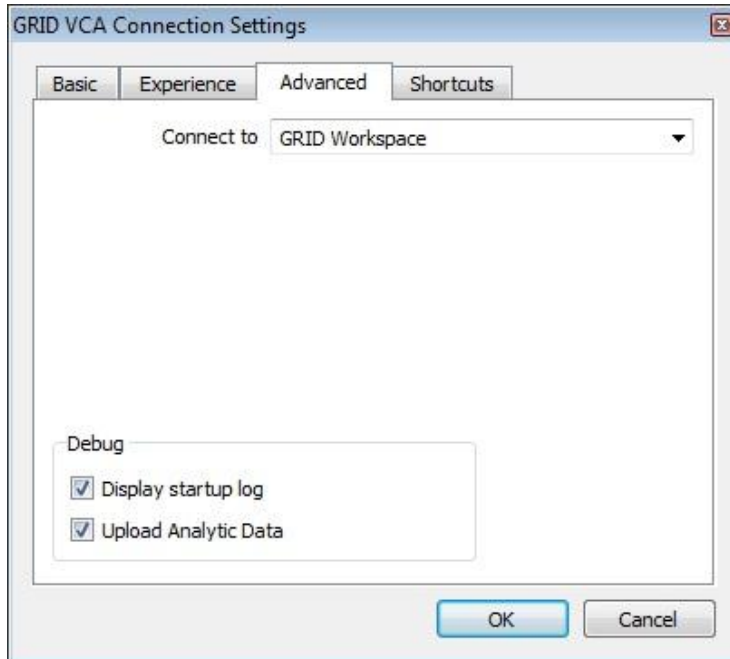

- ▶ **Connect to:** Click the list arrow and select one of the following options:
 - **GRID Workspace:** Standard workspace.
 - **GRID Workspace Maintenance:** Use this setting to connect to the template workspace while in Maintenance Mode.
- ▶ **Debug:**
 - Select the *Display startup log* check box to display in real time debug information at the bottom of the workspace window upon startup.
 - The *Upload Analytic Data* checkbox reflects your response to the request for feedback dialog at installation, shown below. You can change your preference by checking or clearing the checkbox.

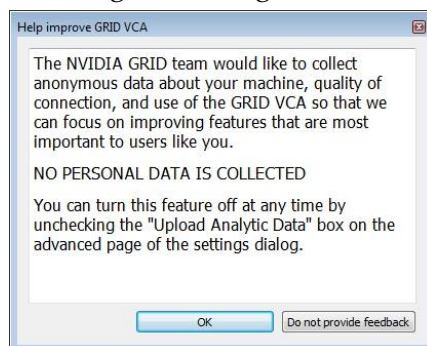

Shortcuts Tab

The *Shortcuts* tab lists the keyboard shortcuts (hot keys) for several GRID Workspace controls, and lets you define your own hot keys.

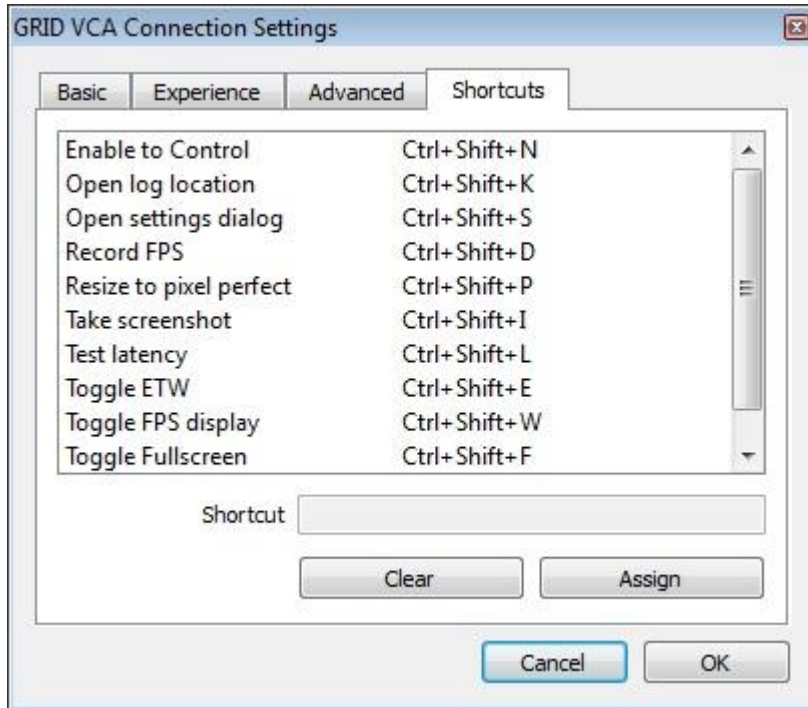

To define a shortcut, do the following:

1. Select a control from the list.
2. Perform the keystrokes that you want to use for the shortcut, holding each key down until the last key is pressed, then releasing all keys.
3. Click **Assign**.

To remove a shortcut, do the following:

1. Select the control from the list and then click **Clear**.
2. Click **OK** when finished setting up your new shortcuts.

You will need to close and then reopen the GRID workspace for the changes to take effect.

THE GRID VCA WEB INTERFACE

THE GRID OPERATOR CONSOLE

1. Open the Operator Console for the GRID VCA Appliance in your browser by going to the URL `http://<GRID Appliance IP>:444`.

Alternately, go to `http://<GRID Appliance IP>` to open the *Workspace Client Downloads* page and then click **Operator Console**.

The *Login* screen appears.

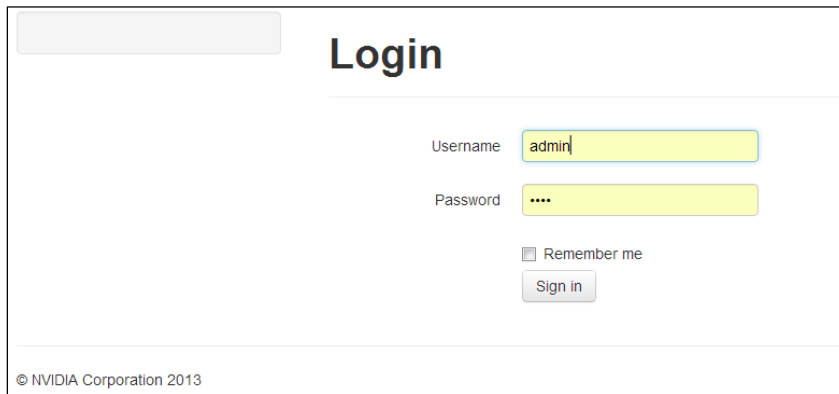

2. Sign in with the following credentials:
 - Username: admin
 - Password: test

The Operator Console opens to the *Overview* page.

OVERVIEW PAGE

From the *Overview* page, you can observe the usage of the VCA as well as alerts from the different components.

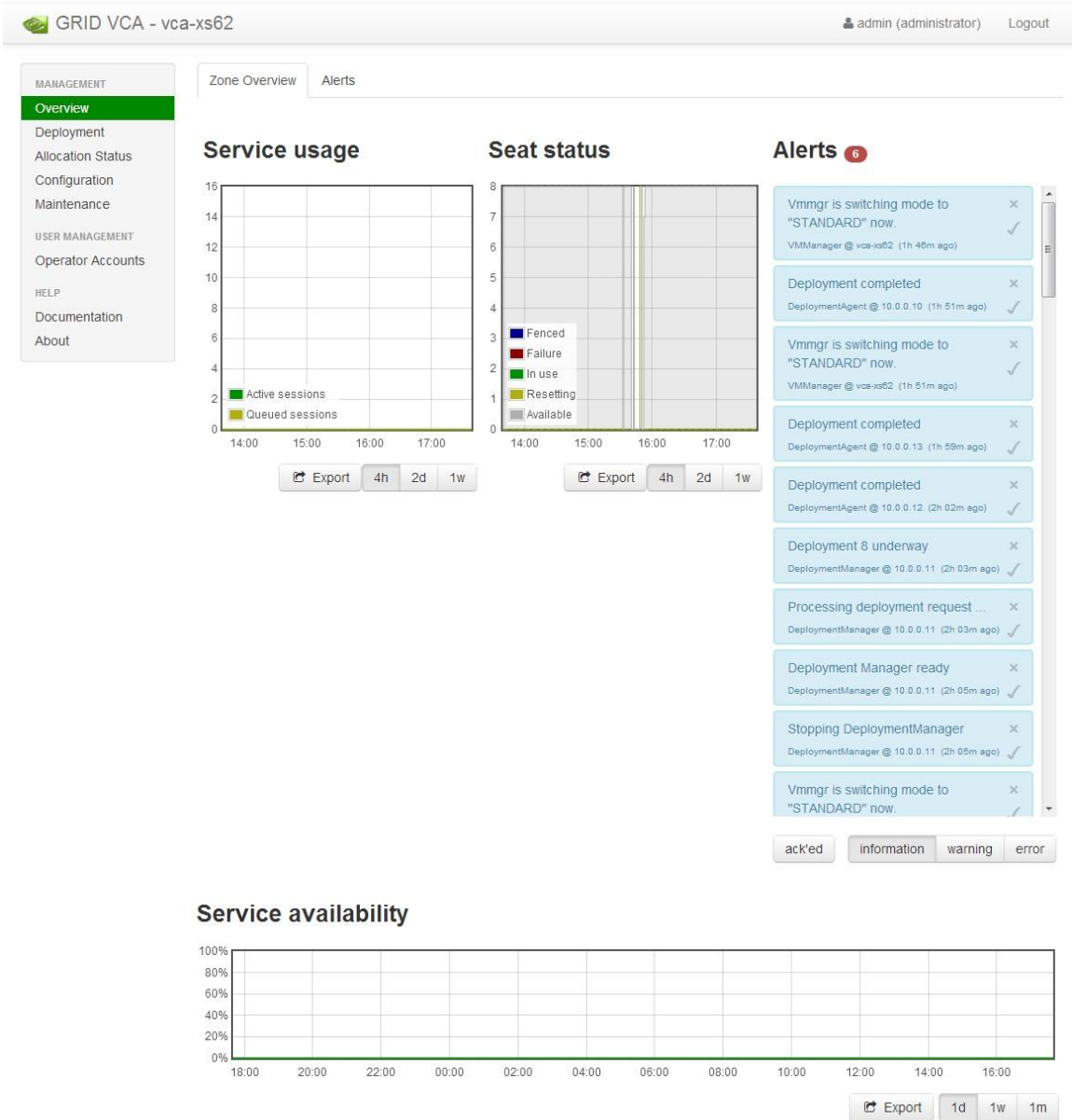

DEPLOYMENT

From the *Deployment* page, you can update the software.

Current Software Tab

GRID VCA - vca-xs62 admin (administrator) Logout

MANAGEMENT
Overview
Deployment
Allocation Status
Configuration
Maintenance

USER MANAGEMENT
Operator
Accounts

HELP
Documentation
About

GRID software deployment

Current software | Install updates | Logs

Last successful at 2014-01-06 15:47:29
Last attempted

Deployment progress

✓ **Updating to version** started at 2014-01-06 15:35:09

- ✓ Downloading update data...
- ✓ OsiServer 10.0.0.11
- ✓ VmManager 10.0.0.10
- ✓ ProvisionManager 10.0.0.13
- ✓ RedisServer 10.0.0.12

No failures detected

Script was last run at 2013-12-19 10:29:46 and terminated after 11s with returncode 0. Show output

Install Updates Tab

The screenshot shows the 'GRID VCA - vca-xs62' interface. The top navigation bar includes the user 'admin (administrator)' and a 'Logout' link. The left sidebar contains a menu with categories: MANAGEMENT (Overview, Deployment, Allocation Status, Configuration, Maintenance), USER MANAGEMENT (Operator Accounts), and HELP (Documentation, About). The 'Deployment' tab is selected. The main content area is titled 'GRID software deployment' and has three sub-tabs: 'Current software', 'Install updates', and 'Logs'. The 'Install updates' tab is active, showing a section for 'Available updates' with a 'Check for updates' button. A message states: 'There are currently no updates available for this GRID zone.' Below this, it notes: 'Only displaying updates published after 2014/01/06, 15:25:38'. To the right, there is a 'Rolling Ratio' slider set to 25% with a 'Restore default' button. At the bottom, there is a 'Manually specify update' section with a 'Manifest ID' input field and a 'Deploy' button.

To update, either click **Deploy** from one of the available packages, or under *Deployment status*, manually specify a manifest and then click **Deploy**.

Logs Tab

The screenshot shows the 'GRID VCA - vca-xs62' interface with the 'Logs' tab selected. The top navigation bar and left sidebar are identical to the previous screenshot. The main content area is titled 'GRID software deployment' and has three sub-tabs: 'Current software', 'Install updates', and 'Logs'. The 'Logs' tab is active, showing a list of deployment log files. The list includes the following manifest IDs: 20131218_184137_ab, 20131218_201424_fb, 20131219_180845_20, 20131230_163736_1a, 20131230_174812_f1, 20131230_182040_30, 20131230_190247_d8, 20140103_185147_8c, 20140104_171426_63, 20140106_160313_98, and 20140106_232459_a4.

These deployment log files are intended for NVIDIA engineering to help root cause when GRID Software updates do not work.

ALLOCATION STATUS

From the *Allocation Status* page, the administrator can

- ▶ Check the state of the virtual machines—whether they are “Free,” “In Use,” “Booting,” or in a “Failed” state.
- ▶ View the connection history of the appliance as well as connection statistics that show how long it took a user to connect to an available seat, and how long their session lasted.

GRID VCA - vca-xs62 admin (administrator) Logout

MANAGEMENT

Overview

Deployment

Allocation Status

Configuration

Maintenance

USER MANAGEMENT

Operator Accounts

HELP

Documentation

About

Seats (orphaned)

Free (8)	In use (-)	Booting (-)	Failure (-)
10.0.0.21,10.0.0.21@10.0.0.10 Perf class: pc_1000			
10.0.0.22,10.0.0.22@10.0.0.10 Perf class: pc_1000			
10.0.0.23,10.0.0.23@10.0.0.10 Perf class: pc_1000			
10.0.0.24,10.0.0.24@10.0.0.10 Perf class: pc_1000			
10.0.0.25,10.0.0.25@10.0.0.10 Perf class: pc_1000			
10.0.0.26,10.0.0.26@10.0.0.10 Perf class: pc_1000			

[▼ Show all](#)



Sessions (orphaned)

	Seat	Virtual Desktop	User	Status
<input checked="" type="checkbox"/>	Seat: 10.0.0.22,10.0.0.22@10.0.0.10 Session: 4a133379-bab0-4f8a-9f89-dcab04d53c1d	Virtual Desktop	sbutt	Requested on 2014-01-06 12:20:24 Waited 0.031s, active 20m 30.762s
<input checked="" type="checkbox"/>	Seat: 10.0.0.24,10.0.0.24@10.0.0.10 Session: 2c36e861-8fe2-47ee-9a25-80bedfd40517	Virtual Desktop	sbutt	Requested on 2014-01-06 10:45:04 Waited 0.016s, active 20m 13.882s
<input checked="" type="checkbox"/>	Seat: 10.0.0.22,10.0.0.22@10.0.0.10 Session: 9df23fa7-6464-4417-9c8a-4db90ff5de27	Virtual Desktop	sbutt	Requested on 2014-01-06 10:03:23 Waited 0.031s, active 20m 14.725s
<input checked="" type="checkbox"/>	Seat: 10.0.0.27,10.0.0.27@10.0.0.10 Session: 1dd0af31-825a-4f33-870a-5395d2bdf9e7	Virtual Desktop	sbutt	Requested on 2014-01-06 08:49:54 Waited 0.016s, active 20m 33.071s
<input checked="" type="checkbox"/>	Seat: 10.0.0.26,10.0.0.26@10.0.0.10 Session: d0de1364-affd-4e2b-8a72-663ebe7ffc53	Virtual Desktop	sbutt	Requested on 2014-01-06 08:49:12 Waited 0.016s, active 4.508s
<input checked="" type="checkbox"/>	Seat: 10.0.0.24,10.0.0.24@10.0.0.10 Session: 2d54e4d8-aa60-4b27-b482-3ef9c819f44e	Virtual Desktop	sbutt	Requested on 2014-01-06 08:46:09 Waited 0.031s, active 30.295s
<input checked="" type="checkbox"/>	Seat: 10.0.0.28,10.0.0.28@10.0.0.10 Session: ...	Virtual Desktop	sbutt	Requested on 2014-01-06 08:41:54 ...

[Export](#) [▼ Show all](#)

Click the reset icon  to reset a seat. Resetting involves a complete reboot of the cloned seat.

The following are the status icons for the list of sessions.

- The session is finished.
-  The session is active.
-  The session is interrupted.

CONFIGURATION

- MANAGEMENT
- Overview
- Deployment
- Allocation Status
- Configuration**
- Maintenance
- USER MANAGEMENT
- Operator Accounts
- HELP
- Documentation
- About

Zone configuration

Log Retention Policy - Number of days to prune logs in GRID Logs Central storage	<input type="text" value="5.0"/>
Streamer Log Retention Policy - Number of days to prune streamer logs in GRID Logs Central storage	<input type="text" value="2.0"/>
Ordered list of ActiveDirectory LDAP servers.	<div><input type="text" value="Insert new"/> <div style="border: 1px solid #ccc; padding: 2px;"><div style="background-color: #f0f0f0; padding: 2px;">LDAP://NVIDIA.com</div></div><div style="text-align: right;"><input type="button" value="Edit"/> <input type="button" value="Delete"/></div></div>
Authentication method	<input checked="" type="checkbox"/> AsgardNoAuth <input checked="" type="checkbox"/> ActiveDirectory1
Compare the zone version numbers and force a client update	<input type="checkbox"/>
Concurrent session limit	<input type="text" value="6"/>
Session disconnect timeout	<input type="text" value="1200"/> seconds
Event Log capture status from workspace	<input checked="" type="checkbox"/>
User input idle timeout (-1 for infinite)	<input type="text" value="-1"/> seconds
Operator Console timeout, after which users (except monitors) are logged out (choose 0 to disable, only takes effect after a page refresh)	<input type="text" value="60"/> minutes
Operator Console timeout (for monitors)	<input type="text" value="0"/> minutes
Name of the Appliance: (Operator Console only)	<input type="text"/>
<input type="button" value="Save changes"/>	

From the *Configuration* page, you can configure the following settings for the GRID zone:

- ▶ **Log Retention Policy** – this applies to most non-streamed logs on the VCA, such as the Deployment log and the GRID Diagnostic log.
- ▶ **Streamer Log Retention Policy** – this applies to streaming logs, such as the Maintenance Audit log.
- ▶ **Ordered list of ActiveDirectory LDAP Servers**
See [Setting Up Active Directory Authentication](#) for more information.
- ▶ **Authentication method:** used to limit access to the GRID VCA. At least one of the following options must be selected:

- **AsgardNoAuth:** With this setting anyone with the address of the GRID VCA is given access. The system does not validate usernames.
- **ActiveDirectory1:** This setting allows authentication using a network domain server. See [Setting Up Active Directory Authentication](#) for more information.
- ▶ Compare the zone version numbers and force a client update
- ▶ **Concurrent session limit:** the maximum number of sessions that can run concurrently
- ▶ **Session disconnect timeout:** the time limit that a session is kept running after the user has disconnected.
- ▶ **Event Log capture status from workspace** – typically, this does not need to be selected. When selected, the Windows Event logs from the client session are gathered and stored in the VCA to assist in diagnosing issues.
- ▶ **Operator Console timeout** - Time limit for users (except for monitors) to be logged in to the Operator Console.
- ▶ **Operator Console timeout** – Time limit for monitors to be logged in to the Operator Console
- ▶ **Name of the Appliance**

MAINTENANCE

From the *Maintenance* page, the administrator can

- ▶ Toggle Maintenance Mode; for example, when setting up a workspace template,
- ▶ Shut down or reboot the zone; for example, if the machine needs to be shut down overnight or moved,
- ▶ Gather logging information for the zone,
- ▶ Specify to which type of network the VCA is connected; typically set automatically,
- ▶ Toggle VNC access to the template virtual machine; for debugging purposes,
- ▶ Specify the number of GPUs in use if you want to adjust the ratio of GPUs to virtual machines,
- ▶ Take a snapshot of the VCA workspace template,
- ▶ Use the sticky note functionality to post notes as reminders.



For any activity, you can click **Cancel** to cancel the operation, or click **Clear output** to clear the displayed text output.

Maintenance Mode

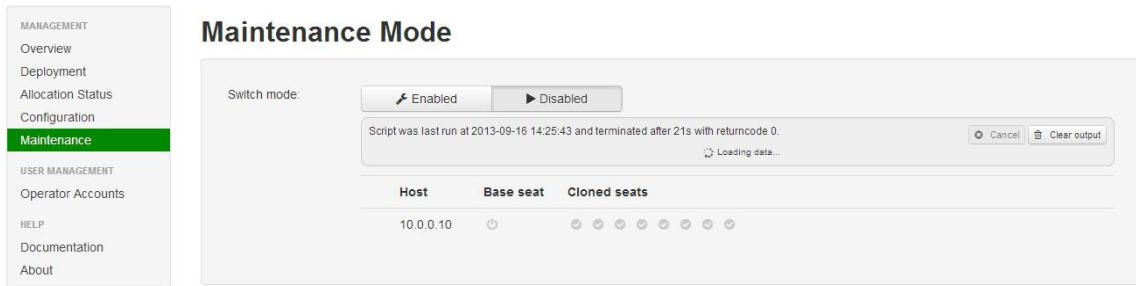
A screenshot of the 'Maintenance Mode' interface. On the left is a navigation menu with categories: MANAGEMENT (Overview, Deployment, Allocation Status, Configuration, Maintenance), USER MANAGEMENT (Operator Accounts), and HELP (Documentation, About). The 'Maintenance' item is highlighted. The main content area is titled 'Maintenance Mode' and features a 'Switch mode:' section with 'Enabled' (selected) and 'Disabled' buttons. Below this is a text box showing a log entry: 'Script was last run at 2013-09-16 14:25:43 and terminated after 21s with returncode 0.' with 'Cancel' and 'Clear output' buttons. At the bottom is a table with columns 'Host', 'Base seat', and 'Cloned seats'. The 'Host' column contains '10.0.0.10' and a power icon. The 'Base seat' column is empty. The 'Cloned seats' column contains seven status icons (circles with checkmarks or power symbols).

This section lets you put the VCA into, or out of, maintenance mode, and also indicates whether maintenance mode is enabled or disabled:

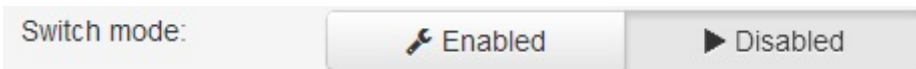

Maintenance Mode Disabled



Maintenance Mode Enabled



This section displays the status of maintenance mode activity.

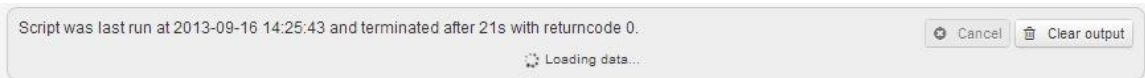

This section shows the Host address, and the state of the base seat as well as each of the cloned seats. The following lists the icons and their meaning

Host	Base seat	Cloned seats
10.0.0.10		

- Seat is ready
- Base seat is shutting down
- Seat is shutting down
- Seat deleted
- Booting seat
- Running a health check
- Waiting for IP
- Cloning seat

Enabling Maintenance Mode

To enable maintenance mode, click the *Switch mode* **Enabled** button.

The process takes several minutes, with the Base seat and Clone seat icons indicating the progress.

The images below indicate that the VCA is in maintenance mode (maintenance mode enabled), the base seat is ready, and all cloned seats are deleted.

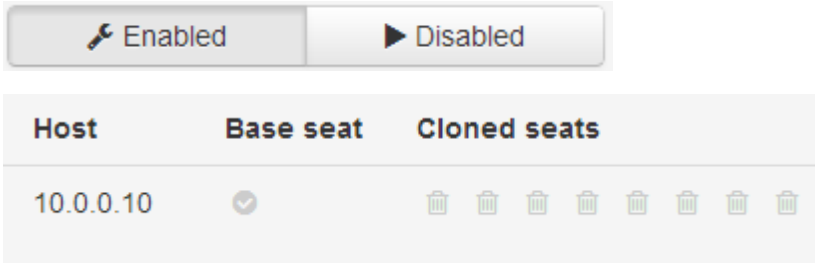

Once in maintenance mode, you can open a maintenance mode workspace.

Note: Only one user can open a Maintenance Mode workspace while in Maintenance Mode. Once a maintenance mode workspace is opened, only that user will have access to the workspace. You will not be able to close it, switch users, and then reopen it.

Disabling Maintenance Mode

To disable maintenance mode, click the *Switch mode* **Disabled** button.

The process takes several minutes, with the Base seat and Clone seat icons indicating the progress.

The images below indicate that the VCA is out of maintenance mode (maintenance mode is disabled), the base seat is shut down, and all cloned seats are ready:

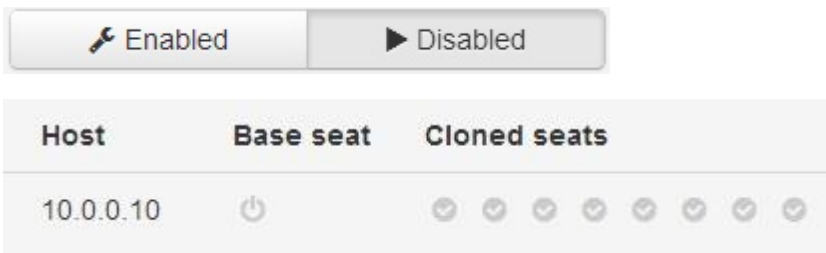

Maintenance Controls

- ▶  Click to run diagnostics on the zone. Basic information resulting from the diagnostics is stored in a tar.gz file. Click the *Diagnostics available [here](#)* link to download the file.

- ▶  Click to run diagnostics on the zone. Complete information resulting from the diagnostics is stored in a tar.gz file. Click the *Diagnostics available [here](#)* link to download the file.

- ▶  Click to shut down and power off the zone; for example, when moving the VCA or if it needs to be shut down overnight.

 **Note:** Once the GRID VCA is shut down you will have to manually start it by pressing the power button.

- ▶  Click to reboot the zone.

▶ Enabling VNC

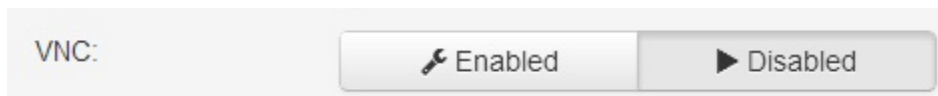

Enable or disable VNC access to the template virtual machine if needed for debug purposes. See [Using VNC To Connect to the GRID VCA](#) for further instructions.

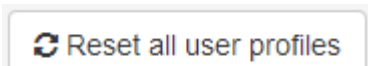
- ▶  Click to delete profile information for all users, including user-specific changes to the GRID Workspace, application customization files, etc. This may be necessary if a particular user's profile becomes corrupt and is experiencing issues with the Workspace as a result.

Using Multiple GPUs per Seats

The GRID VCA is able to quickly re-configure resources in the system. Multiple GPUs and increased system memory and processor cores are incredibly valuable when running multi-GPU aware rendering and simulation applications. Fortunately, the GRID VCA lets you flexibly take advantage of that capability. For example, the GRID VCA can be allocated to eight users during the day but can be quickly converted to an extremely powerful GPU rendering system for overnight rendering.

You can change the per-user resource allocation with the MultiGPU setting.



To change the resource allocation, click the *MultiGPU:Switch to* arrow and select the number of GPUs per user, then click **Change**.

Note: Changing the resource allocation will automatically put the system into maintenance mode, where the system will reallocate the resources. Once complete the system will exit maintenance mode with the new allocation. The change takes between 10 to 15 minutes.

Resources are allocated according to the table below.

Setting	Total # Users	Resource Allocation Per User
1 GPU	8 Users	<ul style="list-style-type: none">• One K5000 class GPU• 30 GB of system memory• 8 virtual processor cores
2 GPU	4 Users	<ul style="list-style-type: none">• Two K5000 class GPUs• 60 GB of system memory• 8 virtual processor cores
4 GPU	2 Users	<ul style="list-style-type: none">• Four K5000 class GPUs• 60 GB of system memory• 16 virtual processor cores
8 GPU	1 User	<ul style="list-style-type: none">• Eight K5000 class GPUs• 60 GB of system memory• 32 virtual processor cores

Using Multiple GPUs with Heavy Workload Applications

Some applications put a heavy load on the GPU.

For example, the CUDA workload for NVIDIA iray® or the multi-GPU Rendering option in Autodesk 3ds Max can take up to 100% of the GPU's resources. This slows down the streaming pipeline and can result in the GRID workspace client becoming unresponsive or even disconnecting.

If you wait for the workload to complete, you can then reconnect to the session. Alternatively, you can use the Multi GPU setting to assign more than one GPU to a seat. If using Multi GPU, be sure to reserve one GPU for streaming the desktop, and allocate the remaining GPUs as necessary for the heavy workload. For example, within NVIDIA iray, do not select the "Used by Windows" GPU when allocating GPU resources as shown below.

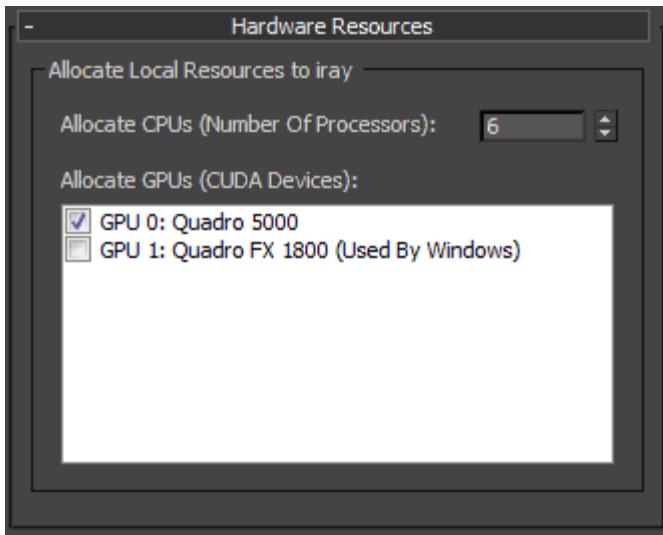

Notifications

Sending Notifications

Send a message to all allocated seats

Message Duration sec

To send a message to all allocated seats,

1. Enter your message in the designated box.
2. Enter how long, in seconds, you want the message to appear.
3. Click **Save** to preserve the message without sending it, or **Save & Send** to send the message.

Using Sticky Notes

Sticky note:

To create a sticky note, enter your note in the space, then click **Post**.

The note will appear in a yellow box at the top of each page of the Admin Console:

The screenshot shows the NVIDIA GRID VCA Admin Console interface. At the top, there is a navigation bar with the logo and the text "GRID VCA" on the left, and the user "admin (administrator)" and a "Logout" link on the right. A yellow sticky note is displayed at the top of the main content area, containing the text "This is a sticky note." Below the sticky note, the "Maintenance Mode" section is visible. It includes a "Switch mode:" section with "Enabled" and "Disabled" buttons. A log entry shows a script starting at 2013-09-30 15:30:05, running for 13s, and putting the system in maintenance mode. Below the log, there is a table with columns for "Host", "Base seat", and "Cloned seats". The "Host" column shows the IP address "10.0.0.10" with a refresh icon. The "Base seat" column shows a power icon. The "Cloned seats" column shows seven green status icons.

Audit Log

Audit Log

```
2014-01-13 22:41:01 -- 172.16.174.53 -- admin -- Deleting user account 'chris_guest' with role guest
2014-01-13 22:41:04 -- 172.16.174.53 -- admin -- Deleting user account 'chris_contentmanager' with role content_manager
2014-01-13 22:41:07 -- 172.16.174.53 -- admin -- Deleting user account 'chris_monitor' with role monitor
2014-01-13 22:41:12 -- 172.16.174.53 -- admin -- Deleting user account 'chris_operator' with role operator
2014-01-14 01:23:35 -- 172.16.174.53 -- admin -- Synchronously executing external command 'sudo /usr/local/asgard/services/Gridpro-Utils/GetSerial.sh' with arguments ''
2014-01-14 02:18:46 -- 172.16.174.53 -- admin -- Downloading file '/var/log/asgard/Deployer/20140110_162257_e8/01' for displaying
2014-01-14 17:35:28 -- 172.16.174.53 -- admin -- Synchronously executing external command 'sudo /usr/local/asgard/services/Gridpro-Utils/GetSerial.sh' with arguments ''
2014-01-14 17:35:57 -- 172.16.174.53 -- admin -- Changing setting disconnecttimeout to 600
2014-01-15 00:01:58 -- 172.16.174.53 -- admin -- Synchronously executing external command 'sudo /usr/local/asgard/services/Gridpro-Utils/GetSerial.sh' with arguments ''
2014-01-15 00:03:27 -- 172.16.174.53 -- admin -- Synchronously executing external command 'sudo /usr/local/asgard/services/Gridpro-Utils/GetSerial.sh' with arguments ''
2014-01-15 00:51:47 -- 172.16.174.53 -- admin -- Starting execution of external command 'sudo /usr/local/asgard/services/Gridpro-Utils/GridDiagnostics.py --d ovrload' with arguments '' and ID 'oneInfo'
2014-01-15 02:18:47 -- 172.16.174.53 -- admin -- Synchronously executing external command 'sudo /usr/local/asgard/services/Gridpro-Utils/GetSerial.sh' with arguments ''
```

The Audit log records different administrative actions performed on the VCA. This is helpful if there are more than one administrator and if an administrator wants to see a history of past actions.

Operator Accounts

From the *Operator Accounts* page, the administrator can create an account for each console operator.

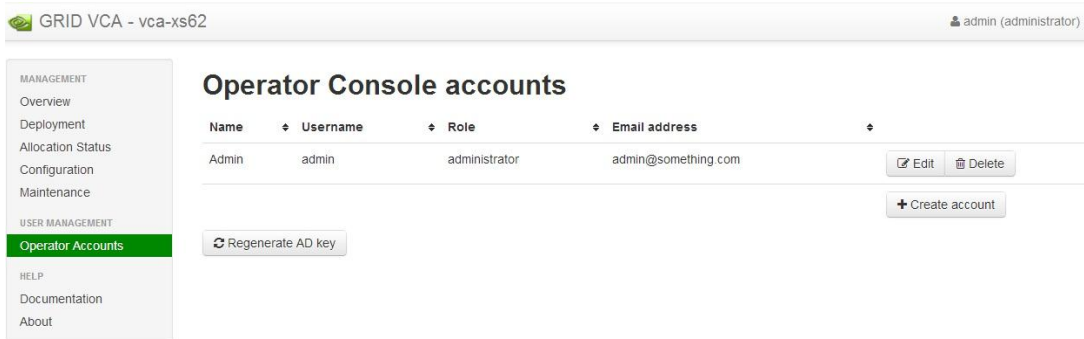

To create an account:

1. Click **Create Account**, and then enter your account information.

Create account

Username *Required*

Realname *Required*

Password *Required*

Email *Required*

Role *Required*

Active

See the table below for details on each role option.

Table 3. Account Roles

GRID Control	Account Role				
	Administrator	Operator	Monitor	Guest	Content Manager
Page Access	All	All	All	Accounts Documentation About	Overview Accounts
Zone Configuration	Yes	Yes	Read-only	No	No
Reset seats	Yes	Yes	No	No	No
Maintenance Controls	Yes	Yes	Read-only	No	No
Deployment Updates	Yes	Yes	Read-only	No	No
Add or delete User accounts	Yes	No	No	No	No

2. Select **Active** to activate the new account, and then click **Save User**.

COMMON ADMINISTRATIVE TASKS

This chapter provides instructions for the following common activities of administrators:

- ▶ [Installing Applications Into the Template Workspace](#)
- ▶ [Connecting to the GRID VCA Using VNC](#)
- ▶ [Setting Up Active Directory Authentication](#)
- ▶ [Connecting to the GRID VCA Remotely](#)
- ▶ [Deploying a New Manifest](#)
- ▶ [Preserving User Settings](#)

INSTALLING APPLICATIONS ON THE TEMPLATE WORKSPACE

To set up a template workspace,

1. Open the NVIDIA GRID Administrator Console.
Using your browser, go to <http://<GRID Appliance IP>:444> and then log in.
2. Enable Maintenance Mode.
 - a) Click **Maintenance** from the left side Management menu.
 - b) Under *Maintenance Mode*, click **Enabled**, if not already depressed.
The switch to maintenance mode will take several minutes to complete.
3. Once the VCA is in maintenance mode, use the GRID Workspace client application to connect to a template workspace.
 - a) Open the GRID Workspace Connection Settings window.
 - b) Click the **Advanced** tab.
 - c) Click the *Connect to* arrow and then select **GRID Workspace Maintenance**.
 - d) Click **OK**.
 - e) Open the GRID Workspace, which should now be in maintenance mode as indicated by the red title bar.

 **Note:** Only one user can open a Maintenance Mode workspace while in Maintenance Mode. Once a maintenance mode workspace is opened, only that user will have access to the workspace. You will not be able to close it, switch users, and then reopen it.

4. From the internet or network storage, install applications, plug-ins, patches, etc. as needed.
 - To install from a USB drive, first copy the files to the GRID Workspace.
See [Copying Files into the GRID Workspace](#) for instructions.
 - To avoid licensing issues, NVIDIA recommends purchasing a network or multi-seat license for applications you plan to install.
5. When completed,
 - a) Open the NVIDIA GRID Administrator Console, go to the *Maintenance* page, and set the Maintenance mode back to **Disabled**.
 - b) Be sure to set the **Connect to** setting on the *GRID Workspace Connection Settings->Advanced* tab back to **GRID Workspace** before opening a GRID workspace.

CONNECTING TO THE GRID VCA USING VNC

Connecting to the GRID VCA using VNC may be necessary for debugging purposes; for example, if you are unable to connect to the GRID maintenance workspace using the standard method then you can connect using VNC as a backup for troubleshooting. This section explains how to do so.

Summary of Steps

1. Get a VNC Client.
2. Enable VNC from the Operator Console.
3. Launch the VNC Application and Connect.

Detailed Instructions

Get a VNC Client

You will need to install VNC client software. Where you get it depends on your operating system:

- ▶ **Windows:** There are several VNC clients for Windows that can be downloaded from the internet, such as RealVNC.
- ▶ **Mac OS:** Screen Sharing is a VNC client that is included with the Mac OS, but requires OS X 10.9.2 or later for VNC GRID access. For Mac OS prior to OS X 10.9.2, use RealVNC for Mac which is available as a free download from the internet.
- ▶ **Linux:** There are several VNC clients that can be downloaded from the internet, such as RealVNC.

Enable VNC from the Operator Console

1. Open the NVIDIA GRID Administrator Console.
Using your browser, go to `https://<GRID Appliance IP>:444` and then log in.
2. Click **Maintenance** from the left side Management menu.
3. Under *Maintenance Controls*, click VNC->**Enabled**, if not already depressed.

The screenshot shows the NVIDIA GRID Administrator Console interface. The top navigation bar includes the NVIDIA GRID logo, the user 'admin (administrator)', and a 'Logout' link. A left-hand menu lists various management options, with 'Maintenance' highlighted in green. The main content area is titled 'Maintenance controls' and contains several sections:

- Gather zone information:** A button to trigger a script. Below it, a status bar shows the script was last run on 2013-08-19 20:22:19 and terminated after 36s with returncode 0. There are 'Cancel' and 'Clear output' buttons.
- Shut down zone:** A button to trigger a script. Below it, a status bar shows the script was last run on 2013-08-21 17:02:27 and terminated after 5m 50s with returncode 0. There are 'Cancel' and 'Clear output' buttons.
- Maintenance mode:** Two radio buttons, 'Enabled' (selected) and 'Disabled'.
- VNC:** Two radio buttons, 'Enabled' (selected) and 'Disabled'. This section is highlighted with a red rectangular box. Below it, a status bar shows the script was last run on 2013-08-21 16:41:42 and terminated after 1s with returncode 0. There are 'Cancel' and 'Clear output' buttons.
- Base image snapshots:** A section with a 'Snapshot name' input field and a 'Take snapshot' button. Below it is a table with columns for 'Date' and 'Name'.
- Sticky note:** A text input field and a 'Post' button.

Connect to the VCA

1. Launch the VNC Client software.
2. Enter the address and password information to connect to the VCA.
 - If the system is in maintenance mode, enter the following
Address: **<GRID Appliance IP>:30021**
Password: **x3n**
 - If the system is not in maintenance mode, then you can connect to one of the workspace seats using the following information:
Address of Seat 1: **<GRID Appliance IP>:30021**
Address of Seat 2: **<GRID Appliance IP>:30022**
Address of Seat 3: **<GRID Appliance IP>:30023**
Address of Seat 4: **<GRID Appliance IP>:30024**
Address of Seat 5: **<GRID Appliance IP>:30025**
Address of Seat 6: **<GRID Appliance IP>:30026**
Address of Seat 7: **<GRID Appliance IP>:30027**
Address of Seat 8: **<GRID Appliance IP>:30028**
Password: **x3n**

INSTALLING THE GRID IMAGE FROM A USB DRIVE

If you have the factory image on a USB flash drive, you can reset the GRID VCA back to the factory image as follows:

1. Attach a keyboard and monitor to the GRID VCA.
2. Insert the USB flash drive into the front USB slot on the GRIDVCA.
3. Power on or reboot the VCA, then press the **F11** key to get to the boot menu.
4. From the boot menu, select the device that corresponds to the USB flash drive:

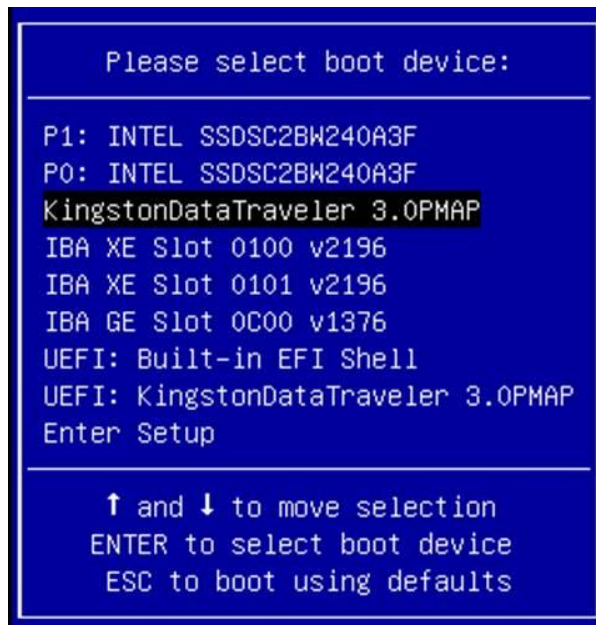

When the system boots off of the USB drive, it will boot a mini Linux kernel and ask if you want to overwrite the current disk drives. Enter 'y':

SETTING UP ACTIVE DIRECTORY AUTHENTICATION

Administrators can restrict access to the GRID VCA by requiring that users use their domain username and password to access the GRID VCA.

1. Open the NVIDIA GRID Administrator Console.

Using your browser, go to `https://<GRID Appliance IP>:444` and then log in.

2. Click **Configuration** from the left side Management menu.
3. At *Ordered list of ActiveDirectory LDAP servers*, enter the URL of the server in the following format:

`LDAP://<server domain>`

Where `<server domain>` is the name of the domain – for example, “`nvidia.com`”.

4. Press **Enter**.

The new URL appears in the list box.



5. At *Authentication method*, clear **AsgardNoAuth** and select **ActiveDirectory1**.

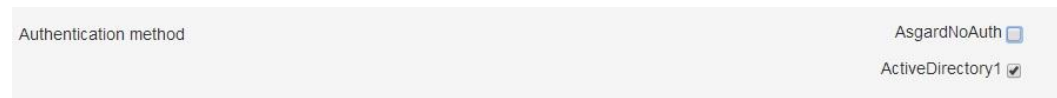

If you leave **AsgardNoAuth** selected, then usernames will not be validated and users are able to access the VCA by providing any username.

6. Click **Save changes**.

Now users attempting a new client connection will need to select the *Active Directory* authentication method from the GRID VCA Connection Settings dialog, and then connect using their domain user name and password.

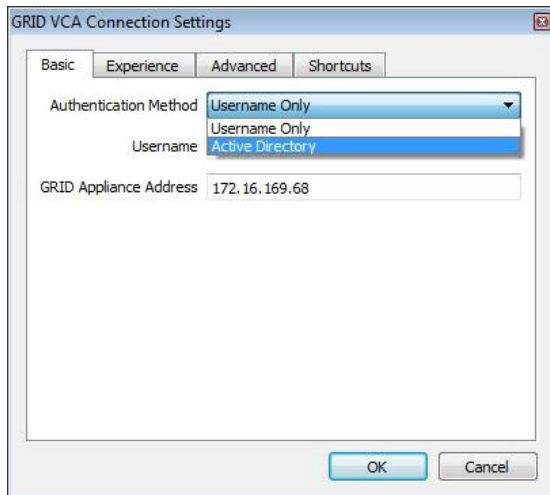

CONNECTING TO THE GRID VCA REMOTELY

Typically there should be no reason to make changes to the VCA using the Setup Console after it has been set up. However, there may be circumstances where it is necessary to modify the setup, such as changing the internal network addressing scheme.

Using SSH

You can access the GRID VCA Setup Console with the secure shell (SSH) protocol using the following:

- ▶ Host Name or IP Address: :<GRID Appliance IP>
- ▶ User: gridadmin
- ▶ Pass: xenserver
- ▶ Command: sudo xsconsole

Using IPMI

If the VCA server is set up for IPMI and you know the address, then you can connect using IPMI. See the section [Configuring an Intelligent Platform Management Interface \(IPMI\)](#) for instructions.

DEPLOYING A NEW MANIFEST

This section describes how to update the GRID VCA software using the Operator Console.

When updating the GRID VCA software

- ▶ There should be no seats in use and users will not be able to open a client workspace.
- ▶ All virtual machines are rebooted.
- ▶ The GRID VCA itself will need to be rebooted to complete the process.

The update process typically takes 30 to 60 minutes to complete, depending on network bandwidth to the NVIDIA server.

1. Open the NVIDIA GRID Operator Console.

Using your browser, go to <https://<GRID Appliance IP>:444> and then log in.

2. Click **Deployment** from the left side Management menu, then click the **Install Updates** tab.

The screenshot shows the NVIDIA GRID VCA Operator Console interface. At the top, it says "GRID VCA - vca-xs62" and "admin (administrator) Logout". The left navigation menu includes "MANAGEMENT" (Overview, Deployment, Allocation Status, Configuration, Maintenance), "USER MANAGEMENT" (Operator Accounts), and "HELP" (Documentation, About). The "Deployment" menu item is highlighted. The main content area is titled "GRID software deployment" and has three tabs: "Current software", "Install updates", and "Logs". The "Install updates" tab is active. Under "Available updates", there is a "Check for updates" button and a message: "There are currently no updates available for this GRID zone." Below this, it says "Only displaying updates published after 2014/01/06, 15:25:38". To the right, there is a "Rolling Ratio" slider set to 25% and a "Restore default" button. Below that is a "Manually specify update" section with a "Manifest ID" input field and a "Deploy" button.

3. Under *Available updates*, select **1.5 R1**.

4. Click **Deploy**.

The view switches to the *Current software* tab and deployment begins.

5. After deployment completes, reboot the GRID VCA as instructed.

PRESERVING USER SETTINGS

On GRID VCA, virtual machines are created when a client workspace is opened, and destroyed when the workspace is closed. Any work that is saved on the workspace during the session is not preserved for the next session.

However, it may be desirable to preserve certain settings.

GRID VCA includes a utility that the system administrator can use, in maintenance mode, to specify files, directories, and registry keys that should be preserved, per user, even when the user disconnects. The utility modifies a configuration file (LaunchData.dat) that contains location information for the files, directories, and registry keys which will be preserved for each user. GRID VCA uses the information in the LaunchData.dat file when destroying a session, and saves the specified files to a persistent location on the VCA. When creating a new client workspace the GRID VCA restores the user-specific information.



Note: Administrators should use caution not to preserve too much user-specific data because this will slow down the whole system. One of the advantages of the GRID VCA is that on every session users are presented with a clean and fast system. Preserving too much user data will negate that benefit.

To edit the user LaunchData.dat file, use the GRID Profile Editor as follows:

1. Open the workspace client in maintenance mode.
 - a) Open the GRID Operator Console and enable Maintenance mode.
 - b) Open the GRID VCA Connection Settings and click the *Advanced* tab.
 - c) Click the **Connect to** drop down arrow and select **GRID Workspace Maintenance**, then click **OK**.
 - d) Open a client workspace.
2. Launch the GRID Profile Editor.
 - a) Navigate to D:\Asgard\Tools\GRID Profile Editor
 - b) Launch GRID Profile Editor.exe.

The GRID Profile Editor opens and loads the Default and User Game Launch Info files. The left hand pane shows the status of the file loads.

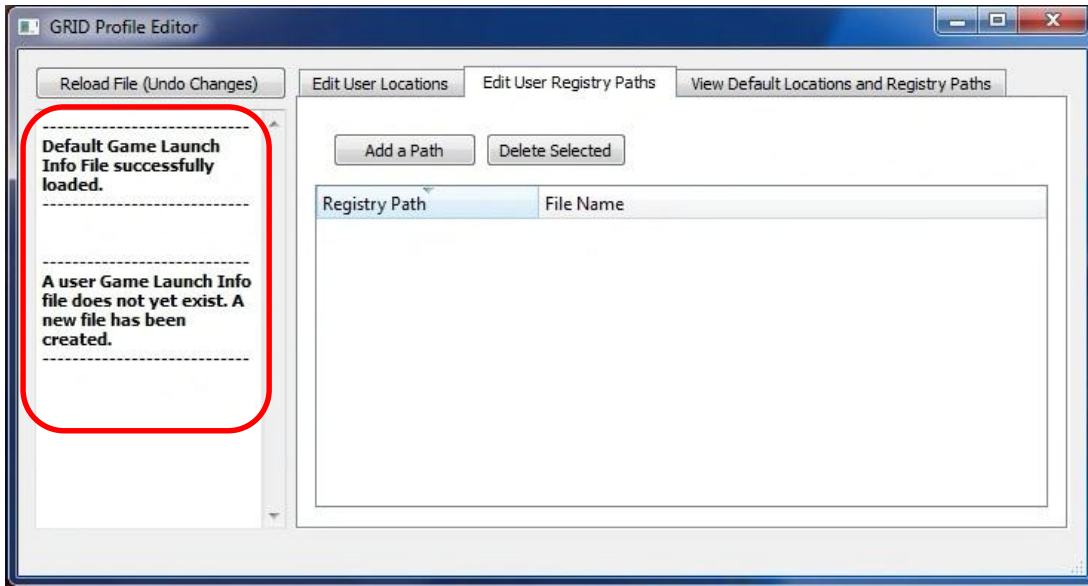

The default LaunchData.dat file specifies information that is preserved for all users, and is located at D:\Asgard\GameLibrary\desktop_prp\000\gameConfig\.

The user LaunchData.dat file, upon creation, is located at D:\User\GameLibrary\desktop_prp\000\gameConfig\.

To view the contents of the default LaunchData.dat file, click the *View Default Locations and Registry Paths* tab.

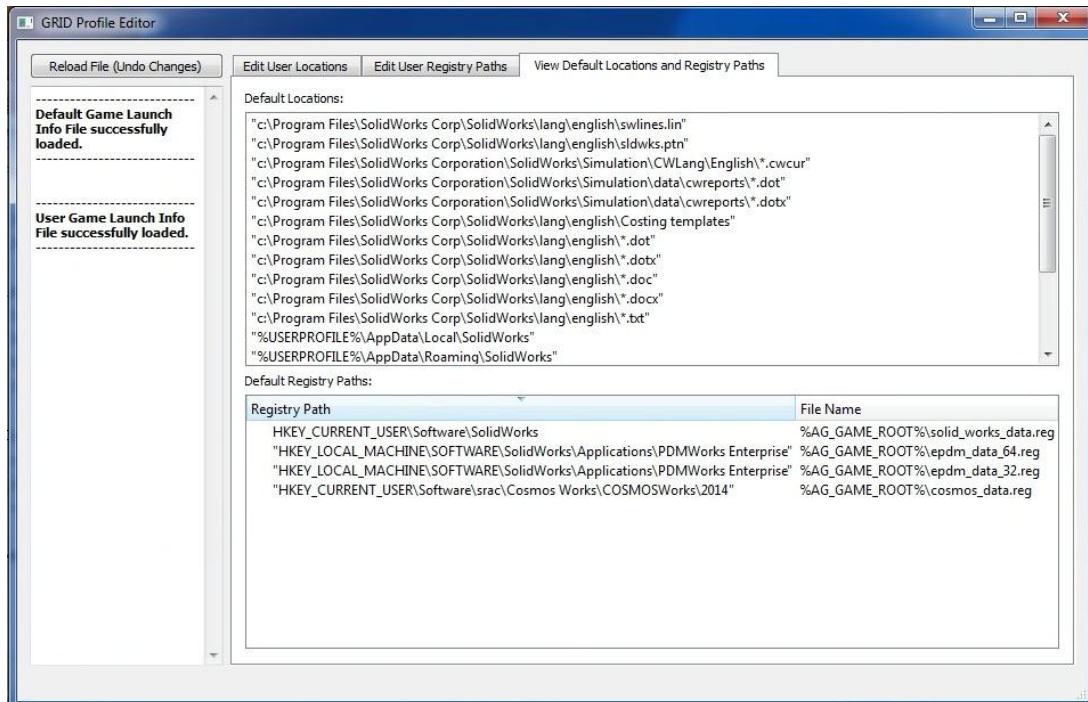

Adding File and Directory Locations

To add files and folders, click the *Edit User Locations* tab.

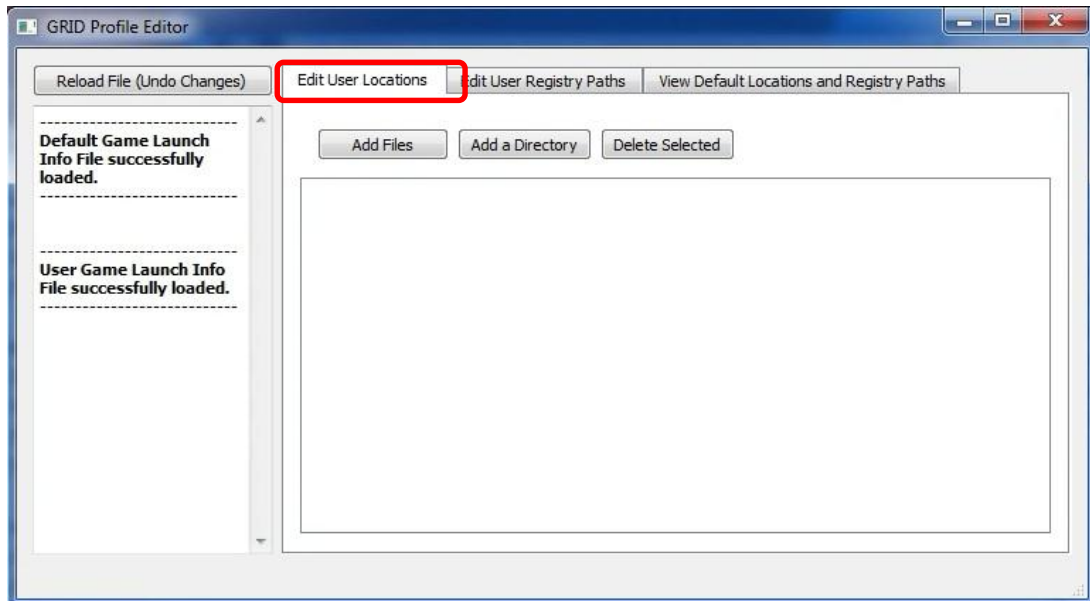

- ▶ To add a file, click **Add Files** and then navigate to the file you want to save and click **Open**.

You can add multiple files by hold the **Ctrl** key while selecting each file.

- ▶ To add a directory, click **Add a Directory** and then navigate to the directory you want to save and click **Select Folder**.

The files and directories that you add are listed in the *Edit User Locations* box. You can delete any entry by selecting it and then clicking **Delete Selected**.

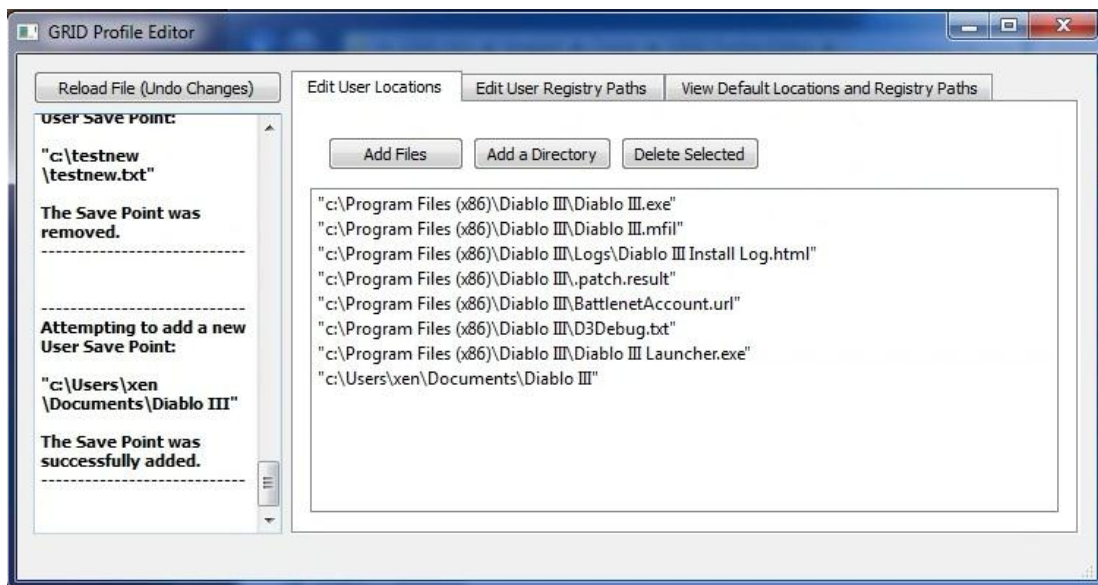

Adding Registry Locations

1. To add a registry path, click the *Edit User Registry Paths* tab.

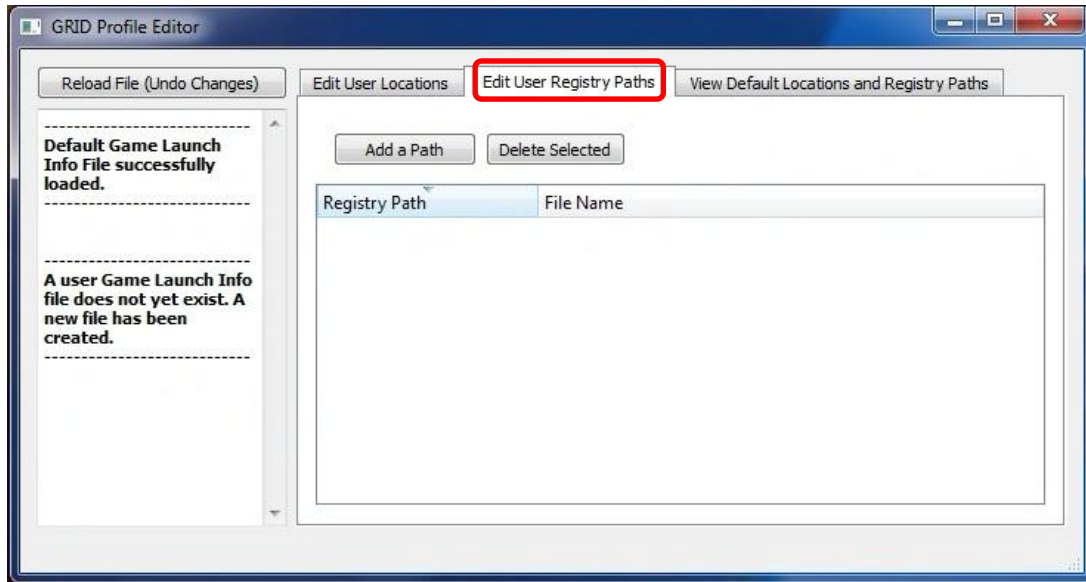

2. Click **Add a Path** and then enter the path to add.

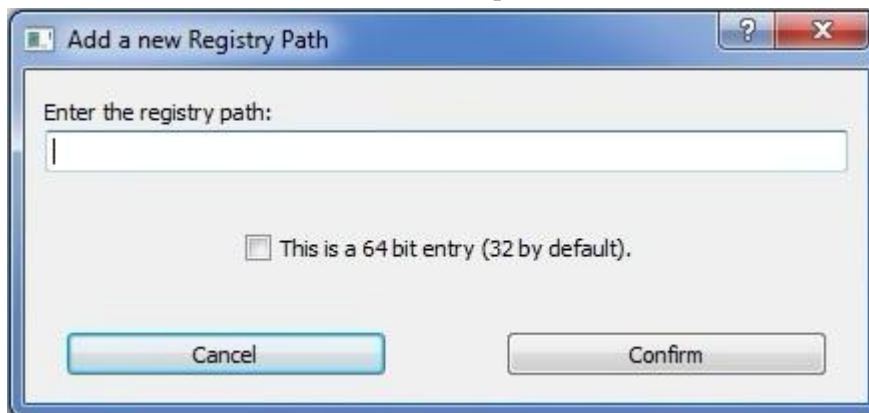

Make sure that the entry is surrounded by double quotes ("").

Example:

"HKEY_LOCAL_MACHINE\SOFTWARE\SolidWorks\Applications\PDMWORKS Enterprise"

3. If the registry path entry is 64 bit, select **This is a 64 bit entry**.

The file names in which these registry paths are stored are automatically generated and displayed in the rightmost column, with a `_32` or `_64` suffix appended, depending on which registry the path applies to. You can delete any entry by selecting it and then clicking **Delete Selected**.

Saving Changes

At any point, you may press the "Reload File (Undo Changes)" button in the upper left to undo all of your changes to the user settings for this session.

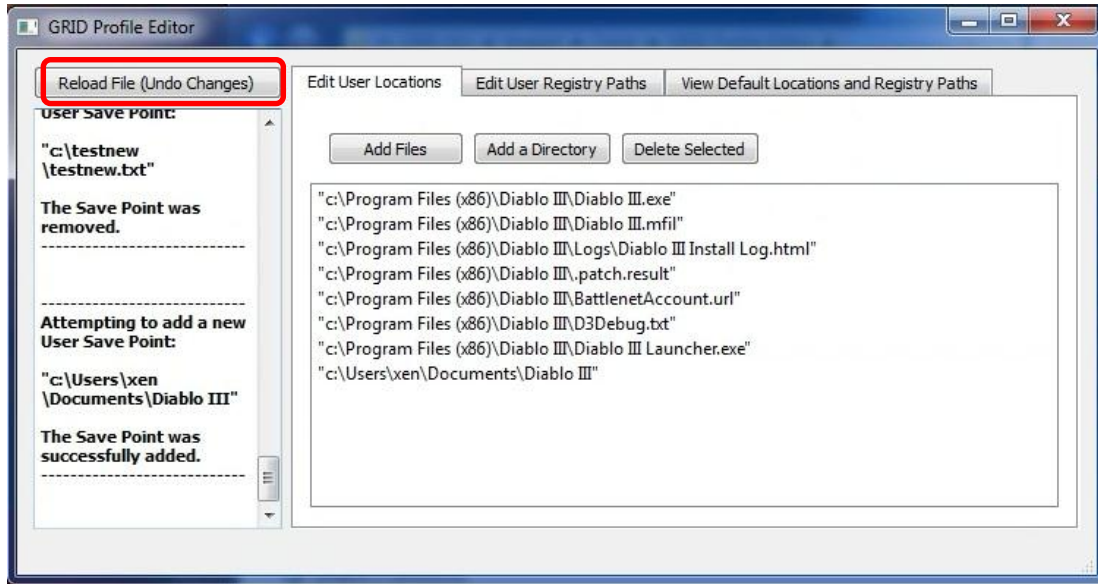

To save your changes, close the window (the red "x" button), and you will be prompted to save changes before you quit.



COMMON CLIENT TASKS

This chapter provides instructions and tips for the following common user activities:

- ▶ [Copying Files into the GRID Workspace](#)
- ▶ [Proper Use of Data Storage](#)

COPYING FILES INTO THE GRID WORKSPACE

To copy a file into the GRID workspace,

1. Drag the files from your client system to anywhere within the GRID workspace window.

A status window appears at the bottom right corner of the workspace, showing the filename and file size of all files that have been copied over during the current session.

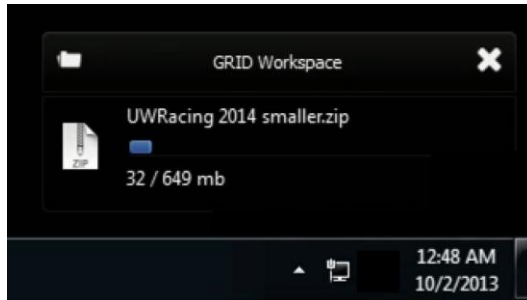

The files are in the `D:\dump` folder.

2. Copy the file to another location, such as the S: drive or desktop, using any of the following methods:
 - Click and then drag the file from the status window.
 - Click the folder icon on the upper left corner of the status window to open the `D:\dump` folder and drag the file from there.

Note: Even when using drag and drop, the files are copied and not moved.

Click the X on the upper right corner of the status window to close the window.

PROPER USE OF DATA STORAGE

The GRID VCA comes with built-in fast network access storage (NAS). This network “scratch” storage is 60 gigabytes in size and is mapped to the S: drive. It is shared amongst all users and is persistent.

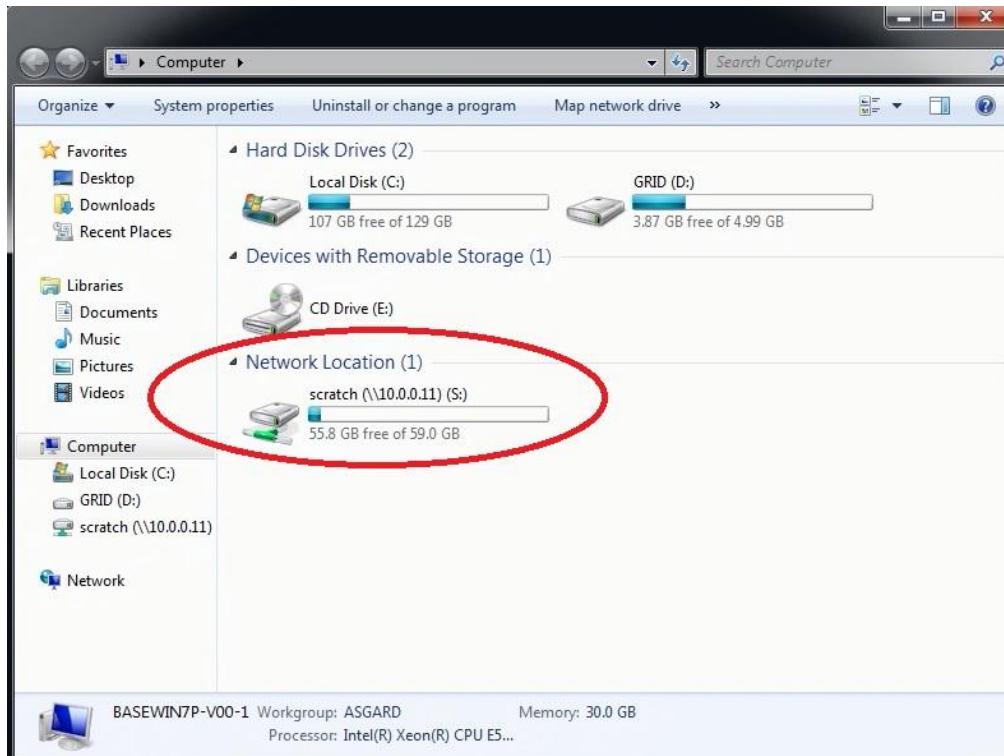

The purpose of this drive is to serve as a scratch space for your data³; it is not intended to replace your NAS and store your company’s valuable data. Moreover, because the GRID VCA does not support user authentication, all of the files and folders created on this scratch space are created by the default user "xen".

Since this drive is intended for scratch space only, users must avoid copying data to the Workspace desktop, and instead save all data (including user settings) to a network share drive or NAS device. Also, do not map an external drive to the S: drive in the Workspace.

³ One example use of the scratch space is to serve as local storage for SolidWorks ePDM. The scratch space built into the appliance is much faster than an external NAS resulting in faster load time for your models.

BEST PRACTICES AND KNOWN ISSUES

BEST PRACTICES FOR USERS

- ▶ Save all data (including user settings) to a network share or Network Attached Storage (NAS) device
- ▶ Refrain from copying data to a Client Workspace desktop

BEST PRACTICES FOR ADMINISTRATORS

The following are considered best practices when deploying a VCA:

- ▶ Use Firefox or Google Chrome to access the Operator Console. Internet Explorer is not a supported browser.
- ▶ Empty the Recycle Bin in the Template Workspace before leaving maintenance mode
- ▶ Use network Licenses for Microsoft Office
- ▶ Use network licenses for Solidworks, Autodesk, and other applications, if at all possible
- ▶ Use GPU-enabled applications for best performance. GPUs are dedicated to each user. CPUs are shared.
- ▶ Limit CPU-intensive applications like those that perform long run jobs
- ▶ Use the Operator Console or xsconsole for all VCA system maintenance
- ▶ Deploy behind an Internet firewall
- ▶ Develop a network bandwidth and latency plan before VCA deployment
- ▶ Connect VCA to a high bandwidth backbone shared with Network Attached Storage for user data. 10Gbit Ethernet is recommended for environments expecting multiple simultaneous large file transfers.

ACTIONS TO AVOID

The following practices are to be avoided:

General

- ▶ Mixing of Workspace Client versions and VCA operating software versions
- ▶ Connecting a VCA to the Internet directly – *VCA does not include storefront security*
- ▶ Running CPU-intensive (analysis) packages on a fully-loaded VCA system
- ▶ Local application licensing

Hardware

- ▶ Connecting to any network port but LAN3
- ▶ Altering or replacing VCA hardware

GRID Workspace Client

- ▶ Changing resolutions of the Windows 7 workspace using “Windows Control Panel -> display -> screen resolution” – *use the Client Workspace settings instead (client restart required)*
- ▶ Logging out of a Windows 7 session using Start->Shutdown->Logoff – *use the Workspace Client -> close box [x] instead.*
- ▶ Selecting shutdown in Windows 7 using Start->Shutdown. – *use the Workspace Client -> close box [x] instead.*
- ▶ Mapping an external share to the S: Drive in the Workspace. (The S: drive is reserved for the internal VCA storage cache)

GRID Workspace Template

- ▶ Changing the IP address
- ▶ Turning on Windows firewall
- ▶ Turning on Windows updates (see [Known Issues](#) section)
- ▶ Installing Windows antivirus tools (see [Known Issues](#) section)
- ▶ Changing resolutions of the Windows 7 workspace using “Windows Control Panel -> display -> screen resolution” – *use the Client Workspace settings instead (client restart required)*
- ▶ Logging out of a Windows 7 session using Start->Shutdown->Logoff – *use the Workspace Client -> close box [x] instead.*

- ▶ Selecting shutdown in Windows 7 using Start->Shutdown. – *use the Workspace Client - > close box [x] instead.*
- ▶ Full implementation of Active Directory
- ▶ Destroying, damaging, or reimaging of the Template Workspace Windows 7 operating system
- ▶ Local application licensing (node-locked licensing of applications)
- ▶ Mapping an external share to the S: Drive in the Workspace Template. (The S: drive is reserved for the internal VCA storage cache)

GRID Maintenance

- ▶ Using 3rd party hypervisor management tools
- ▶ Turning on VNC before switching to maintenance mode - *VNC should only be enabled while in Maintenance mode and disabled before leaving Maintenance mode*
- ▶ In general, one should avoid entering the administrative command shells unless otherwise instructed by support personnel.
- ▶ Redeploying, overinstalling, or reverting to a previous release of VCA operation software from the Operator Console -> Deployment page.
- ▶ Using Internet Explorer for accessing the Operator Console - *Use Chrome Browser or Firefox instead since these are supported on all target client OS's*
- ▶ Destroying, damaging, or reimaging of the Template Workspace Windows 7 operating system

Hypervisor

- ▶ Making manual changes to the hypervisor settings using SSH, unless specified by support personnel
- ▶ Using Linux commands to perform system maintenance or networking configuration
- ▶ Using 3rd party hypervisor management tools
- ▶ Using Linux shutdown commands in the hypervisor

KNOWN ISSUES

Windows Updates or antivirus software may conflict with the template workspace.

NVIDIA recommends that Windows Update be disabled and antivirus software not installed on the template workspace.

If it is critical to enable Windows Update or install antivirus software, first back up the template (see the section [Saving and Importing the Template](#) for instructions).

If the template gets corrupted as the result of a Windows Update or antivirus application, then restore the template and contact NVIDIA for assistance in investigating the issue.

Two cursors appear when increasing Adobe Photoshop brush size.

COMPLIANCE

The NVIDIA GRID equipment is compliant with the following regulations:

- ▶ Federal Communications Commission (FCC)
- ▶ Industry Canada (IC)
- ▶ Conformité Européenne (CE)
- ▶ Australian Communications and Media Authority (C-tick)
- ▶ Voluntary Control Council for Interference (VCCI)
- ▶ Bureau of Standards Metrology and Inspection (BSMI)
- ▶ Korean Certification (KC)
- ▶ Underwriters Laboratories (UL, cUL)
- ▶ ISO 9241-307 Visual Display Ergonomics

UNITED STATES

Federal Communications Commission (FCC)



This equipment has been tested and found to comply with the limits for a Class B digital device, pursuant to Part 15 of the FCC Rules. These limits are designed to provide reasonable protection against harmful interference in a residential installation. This equipment generates, uses, and can radiate radio frequency energy and, if not installed and used in accordance with the instructions, may cause harmful interference to radio communications. However, there is no guarantee that interference will not occur in a particular installation.

If this equipment does cause harmful interference to radio or television reception, which can be determined by turning the equipment off and on, the user is encouraged to try to correct the interference by one or more of the following measures:

- ▶ Reorient or relocate the receiving antenna.
- ▶ Increase the separation between the equipment and receiver.
- ▶ Connect the equipment into an outlet on a circuit different from that to which the receiver is connected.
- ▶ Consult the dealer or

INDUSTRY CANADA (IC)

**This Class B digital apparatus complies with ICES-003
Cet appareil numérique de la classe B est conforme à la norme
NMB-003 du Canada.**

Operation is subject to the following two conditions: (1) this device may not cause interference, and (2) this device must accept any interference, including interference that may cause undesired operation of the device.

EUROPEAN UNION

European Conformity; Conformité Européenne (CE)



This device complies with the EMC Directive for Class B, I.T.E equipment.

AUSTRALIA & NEW ZEALAND

Australian Communications and Media Authority (C-tick)



This product meets the applicable EMC requirements for Class B, I.T.E equipment.

JAPAN

Voluntary Control Council for Interference (VCCI)



この装置は、クラスB 情報技術装置です。この装置は、家庭環境で使用することを目的としていますが、この装置がラジオやテレビジョン受信機に近接して使用されると、受信障害を引き起こすことがあります。

取扱説明書に従って正しい取り扱いをして下さい。

VCCI-B

This is a Class B product based on the standard of the VCCI Council. If this is used near a radio or television receiver in a domestic environment, it may cause radio interference. Install and use the equipment according to the instruction manual.

KOREA

Radio Research Agency (RRA)



KCC-REM-NVA-P2030

B급 기기(가정용 방송통신기기)

이 기기는 가정용(B급)으로 전자파적합등록을 한 기기로서 주로 가정에서 사용하는 것을 목적으로 하며, 모든 지역에서 사용할 수 있습니다.

Class B Equipment (For Home Use Broadcasting & Communication Equipment)

This equipment is home use (Class B) electromagnetic wave suitability equipment and to be used mainly at home and it can be used in all areas.

TAIWAN COMPLIANCE

Bureau of Standards, Metrology and Inspection (BSMI)



D33088

This device complies with CNS 13438 (2006) Class B

SAFETY

Underwriters Laboratories (UL)



Notice

The information provided in this specification is believed to be accurate and reliable as of the date provided. However, NVIDIA Corporation (“NVIDIA”) does not give any representations or warranties, expressed or implied, as to the accuracy or completeness of such information. NVIDIA shall have no liability for the consequences or use of such information or for any infringement of patents or other rights of third parties that may result from its use. This publication supersedes and replaces all other specifications for the product that may have been previously supplied.

NVIDIA reserves the right to make corrections, modifications, enhancements, improvements, and other changes to this specification, at any time and/or to discontinue any product or service without notice. Customer should obtain the latest relevant specification before placing orders and should verify that such information is current and complete.

NVIDIA products are sold subject to the NVIDIA standard terms and conditions of sale supplied at the time of order acknowledgement, unless otherwise agreed in an individual sales agreement signed by authorized representatives of NVIDIA and customer. NVIDIA hereby expressly objects to applying any customer general terms and conditions with regard to the purchase of the NVIDIA product referenced in this specification.

NVIDIA products are not designed, authorized or warranted to be suitable for use in medical, military, aircraft, space or life support equipment, nor in applications where failure or malfunction of the NVIDIA product can reasonably be expected to result in personal injury, death or property or environmental damage. NVIDIA accepts no liability for inclusion and/or use of NVIDIA products in such equipment or applications and therefore such inclusion and/or use is at customer’s own risk.

NVIDIA makes no representation or warranty that products based on these specifications will be suitable for any specified use without further testing or modification. Testing of all parameters of each product is not necessarily performed by NVIDIA. It is customer’s sole responsibility to ensure the product is suitable and fit for the application planned by customer and to do the necessary testing for the application in order to avoid a default of the application or the product. Weaknesses in customer’s product designs may affect the quality and reliability of the NVIDIA product and may result in additional or different conditions and/or requirements beyond those contained in this specification. NVIDIA does not accept any liability related to any default, damage, costs or problem which may be based on or attributable to: (i) the use of the NVIDIA product in any manner that is contrary to this specification, or (ii) customer product designs.

No license, either expressed or implied, is granted under any NVIDIA patent right, copyright, or other NVIDIA intellectual property right under this specification. Information published by NVIDIA regarding third-party products or services does not constitute a license from NVIDIA to use such products or services or a warranty or endorsement thereof. Use of such information may require a license from a third party under the patents or other intellectual property rights of the third party, or a license from NVIDIA under the patents or other intellectual property rights of NVIDIA. Reproduction of information in this specification is permissible only if reproduction is approved by NVIDIA in writing, is reproduced without alteration, and is accompanied by all associated conditions, limitations, and notices.

ALL NVIDIA DESIGN SPECIFICATIONS, REFERENCE BOARDS, FILES, DRAWINGS, DIAGNOSTICS, LISTS, AND OTHER DOCUMENTS (TOGETHER AND SEPARATELY, “MATERIALS”) ARE BEING PROVIDED “AS IS.” NVIDIA MAKES NO WARRANTIES, EXPRESSED, IMPLIED, STATUTORY, OR OTHERWISE WITH RESPECT TO THE MATERIALS, AND EXPRESSLY DISCLAIMS ALL IMPLIED WARRANTIES OF NONINFRINGEMENT, MERCHANTABILITY, AND FITNESS FOR A PARTICULAR PURPOSE. Notwithstanding any damages that customer might incur for any reason whatsoever, NVIDIA’s aggregate and cumulative liability towards customer for the products described herein shall be limited in accordance with the NVIDIA terms and conditions of sale for the product..

Trademarks

NVIDIA, the NVIDIA logo, Kepler, NVIDIA GRID, and Quadro are trademarks and/or registered trademarks of NVIDIA Corporation in the U.S. and other countries. Other company and product names may be trademarks of the respective companies with which they are associated.

Copyright

© 2013, 2014 NVIDIA Corporation. All rights reserved.

THIRD-PARTY LICENSES

This NVIDIA product contains third party software that is being made available to you under their respective open source software licenses. Some of those licenses also require specific legal information to be included in the product. This chapter provides such information.

OPEN SOURCE SOFTWARE

The software listed below is provided under the terms of the specified open source software licenses.

To obtain source code for software provided under licenses that require redistribution of source code, including the GNU General Public License (GPL) and GNU Lesser General Public License (LGPL), contact oss-requests@nvidia.com.

This offer is valid for a period of three (3) years from the date of the distribution of this product by NVIDIA CORPORATION.

Component	License
Qt 5	LGPL v2.1

GNU LESSER GENERAL PUBLIC LICENSE

Version 2.1, February 1999

Copyright (C) 1991, 1999 Free Software Foundation, Inc. 51 Franklin Street, Fifth Floor, Boston, MA 02110-1301 USA

Everyone is permitted to copy and distribute verbatim copies of this license document, but changing it is not allowed.

[This is the first released version of the Lesser GPL. It also counts as the successor of the GNU Library Public License, version 2, hence the version number 2.1.]

PREAMBLE

The licenses for most software are designed to take away your freedom to share and change it. By contrast, the GNU General Public Licenses are intended to guarantee your freedom to share and change free software--to make sure the software is free for all its users.

This license, the Lesser General Public License, applies to some specially designated software packages--typically libraries--of Software Foundation and other authors who decide to use it. You can use it too, but we suggest you first think carefully about whether this license or the ordinary General Public License is the better strategy to use in any particular case, based on the explanations below.

When we speak of free software, we are referring to freedom of use, not price. Our General Public Licenses are designed to make sure that you have the freedom to distribute copies of free software (and charge for this service if you wish); that you receive source code or can get it if you want it; that you can change the software and use pieces of it in new free programs; and that you are informed that you can do these things.

To protect your rights, we need to make restrictions that forbid distributors to deny you these rights or to ask you to surrender these rights. These restrictions translate to certain responsibilities for you if you distribute copies of the library or if you modify it.

For example, if you distribute copies of the library, whether gratis or for a fee, you must give the recipients all the rights that we gave you. You must make sure that they, too, receive or can get the source code. If you link other code with the library, you must provide complete object files to the recipients, so that they can relink them with the library after making changes to the library and recompiling it. And you must show them these terms so they know their rights.

We protect your rights with a two-step method: (1) we copyright the library, and (2) we offer you this license, which gives you legal permission to copy, distribute and/or modify the library.

To protect each distributor, we want to make it very clear that there is no warranty for the free library. Also, if the library is modified by someone else and passed on, the recipients should know that what they have is not the original version, so that the original author's reputation will not be affected by problems that might be introduced by others.

Finally, software patents pose a constant threat to the existence of any free program. We wish to make sure that a company cannot effectively restrict the users of a free program by obtaining a restrictive license from a patent holder. Therefore, we insist that any patent license obtained for a version of the library must be consistent with the full freedom of use specified in this license.

Most GNU software, including some libraries, is covered by the ordinary GNU General Public License. This license, the GNU Lesser General Public License, applies to certain designated libraries, and is quite different from the ordinary General Public License. We use this license for certain libraries in order to permit linking those libraries into non-free programs.

When a program is linked with a library, whether statically or using a shared library, the combination of the two is legally speaking a combined work, a derivative of the original library. The ordinary General Public License therefore permits such linking only if the entire combination fits its criteria of freedom. The Lesser General Public License permits more lax criteria for linking other code with the library.

We call this license the "Lesser" General Public License because it does Less to protect the user's freedom than the ordinary General Public License. It also provides other free software developers less of an advantage over competing non-free programs.

These disadvantages are the reason we use the ordinary General Public License for many libraries. However, the Lesser license provides advantages in certain special circumstances.

For example, on rare occasions, there may be a special need to encourage the widest possible use of a certain library, so that it becomes a de-facto standard. To achieve this, non-free programs must be allowed to use the library. A more frequent case is that a free library does the same job as widely used non-free libraries. In this case, there is little to gain by limiting the free library to free software only, so we use the Lesser General Public License.

In other cases, permission to use a particular library in non-free programs enables a greater number of people to use a large body of free software. For example, permission to use the GNU C Library in non-free programs enables many more people to use the whole GNU operating system, as well as its variant, the GNU/Linux operating system.

Although the Lesser General Public License is less protective of the users' freedom, it does ensure that the user of a program that is linked with the Library has the freedom and the wherewithal to run that program using a modified version of the Library.

The precise terms and conditions for copying, distribution and modification follow. Pay close attention to the difference between a "work based on the library" and a "work that uses the library". The former contains code derived from the library, whereas the latter must be combined with the library in order to run.

GNU LESSER GENERAL PUBLIC LICENSE

TERMS AND CONDITIONS FOR COPYING, DISTRIBUTION AND MODIFICATION

0. This License Agreement applies to any software library or other program which contains a notice placed by the copyright holder or other authorized party saying it may be distributed under the terms of this Lesser General Public License (also called "this License"). Each licensee is addressed as "you".

A "library" means a collection of software functions and/or data prepared so as to be conveniently linked with application programs (which use some of those functions and data) to form executables.

The "Library", below, refers to any such software library or work which has been distributed under these terms. A "work based on the Library" means either the Library or any derivative work under copyright law: that is to say, a work containing the Library or a portion of it, either verbatim or with modifications and/or translated straightforwardly into another language. (Hereinafter, translation is included without limitation in the term "modification".)

"Source code" for a work means the preferred form of the work for making modifications to it. For a library, complete source code means all the source code for all modules it contains, plus any associated interface definition files, plus the scripts used to control compilation and installation of the library.

Activities other than copying, distribution and modification are not covered by this License; they are outside its scope. The act of running a program using the Library is not restricted, and output from such a program is covered only if its contents constitute a work based on the Library (independent of the use of the Library in a tool for writing it). Whether that is true depends on what the Library does and what the program that uses the Library does.

1. You may copy and distribute verbatim copies of the Library's complete source code as you receive it, in any medium, provided that you conspicuously and appropriately publish on each copy an appropriate copyright notice and disclaimer of warranty; keep intact all the notices that refer to this License and to the absence of any warranty; and distribute a copy of this License along with the Library. You may charge a fee for the physical act of transferring a copy, and you may at your option offer warranty protection in exchange for a fee.

2. You may modify your copy or copies of the Library or any portion of it, thus forming a work based on the Library, and copy and distribute such modifications or work under the terms of Section 1 above, provided that you also meet all of these conditions:

- a) The modified work must itself be a software library.
- b) You must cause the files modified to carry prominent notices stating that you changed the files and the date of any change.
- c) You must cause the whole of the work to be licensed at no charge to all third parties under the terms of this License.
- d) If a facility in the modified Library refers to a function or a table of data to be supplied by an application program that uses the facility, other than as an argument passed when the facility is invoked, then you must make a good faith effort to ensure that, in the event an application does not supply such function or table, the facility still operates, and performs whatever part of its purpose remains meaningful.

(For example, a function in a library to compute square roots has a purpose that is entirely well-defined independent of the application. Therefore, Subsection 2d requires that any application-supplied function or table used by this function must be optional: if the application does not supply it, the square root function must still compute square roots.)

These requirements apply to the modified work as a whole. If identifiable sections of that work are not derived from the Library, and can be reasonably considered independent and separate works in themselves, then this License, and its terms, do not apply to those sections when you distribute them as separate works. But when you distribute the same sections as part of a whole which is a work based on the Library, the distribution of the whole must be on the terms of this License, whose permissions for other licensees extend to the entire whole, and thus to each and every part regardless of who wrote it.

Thus, it is not the intent of this section to claim rights or contest your rights to work written entirely by you; rather, the intent is to exercise the right to control the distribution of derivative or collective works based on the Library. In addition, mere aggregation of another work not based on the Library with the Library (or with a work based on the Library) on a volume of a storage or distribution medium does not bring the other work under the scope of this License.

3. You may opt to apply the terms of the ordinary GNU General Public License instead of this License to a given copy of the Library. To do this, you must alter all the notices that refer to this License, so that they refer to the ordinary GNU General Public License, version 2, instead of to this License. (If a newer version than version 2 of the ordinary GNU General Public License has appeared, then you can specify that version instead if you wish.) Do not make any other change in these notices. Once this change is made in a given copy, it is irreversible for that copy, so the ordinary GNU General Public License applies to

all subsequent copies and derivative works made from that copy. This option is useful when you wish to copy part of the code of the Library into a program that is not a library.

4. You may copy and distribute the Library (or a portion or derivative of it, under Section 2) in object code or executable form under the terms of Sections 1 and 2 above provided that you accompany it with the complete corresponding machine-readable source code, which must be distributed under the terms of Sections 1 and 2 above on a medium customarily used for software interchange. If distribution of object code is made by offering access to copy from a designated place, then offering equivalent access to copy the source code from the same place satisfies the requirement to distribute the source code, even though third parties are not compelled to copy the source along with the object code.

5. A program that contains no derivative of any portion of the Library, but is designed to work with the Library by being compiled or linked with it, is called a "work that uses the Library". Such a work, in isolation, is not a derivative work of the Library, and therefore falls outside the scope of this License. However, linking a "work that uses the Library" with the Library creates an executable that is a derivative of the Library (because it contains portions of the Library), rather than a "work that uses the library". The executable is therefore covered by this License. Section 6 states terms for distribution of such executables. When a "work that uses the Library" uses material from a header file that is part of the Library, the object code for the work may be a derivative work of the Library even though the source code is not. Whether this is true is especially significant if the work can be linked without the Library, or if the work is itself a library. The threshold for this to be true is not precisely defined by law. If such an object file uses only numerical parameters, data structure layouts and accessors, and small macros and small inline functions (ten lines or less in length), then the use of the object file is unrestricted, regardless of whether it is legally a derivative work. (Executables containing this object code plus portions of the Library will still fall under Section 6.) Otherwise, if the work is a derivative of the Library, you may distribute the object code for the work under the terms of Section 6. Any executables containing that work also fall under Section 6, whether or not they are linked directly with the Library itself.

6. As an exception to the Sections above, you may also combine or link a "work that uses the Library" with the Library to produce a work containing portions of the Library, and distribute that work under terms of your choice, provided that the terms permit modification of the work for the customer's own use and reverse engineering for debugging such modifications. You must give prominent notice with each copy of the work that the Library is used in it and that the Library and its use are covered by this License. You must supply a copy of this License. If the work during execution displays copyright notices, you must include the copyright notice for the Library among them, as well as a reference directing the user to the copy of this License. Also, you must do one of these things:

a) Accompany the work with the complete corresponding machine-readable source code for the Library including whatever changes were used in the work (which must be distributed under Sections 1 and 2 above); and, if the work is an executable linked with the Library, with the complete machine-readable "work that uses the Library", as object code and/or source code, so that the user can modify the Library and then relink to produce a modified executable containing the modified Library. (It is understood that the user who changes the contents of definitions files in the Library will not necessarily be able to recompile the application to use the modified definitions.)

b) Use a suitable shared library mechanism for linking with the Library. A suitable mechanism is one that (1) uses at run time a copy of the library already present on the user's computer system, rather than copying library functions into the executable, and (2) will operate properly with a modified version of the library, if the user installs one, as long as the modified version is interface-compatible with the version that the work was made with.

c) Accompany the work with a written offer, valid for at least three years, to give the same user the materials specified in Subsection 6a, above, for a charge no more than the cost of performing this distribution.

d) If distribution of the work is made by offering access to copy from a designated place, offer equivalent access to copy the above specified materials from the same place.

e) Verify that the user has already received a copy of these materials or that you have already sent this user a copy.

For an executable, the required form of the "work that uses the Library" must include any data and utility programs needed for reproducing the executable from it. However, as a special exception, the materials to be distributed need not include anything that is normally distributed (in either source or binary form) with the major components (compiler, kernel, and so on) of the operating system on which the executable runs, unless that component itself accompanies the executable. It may happen that this requirement contradicts the license restrictions of other proprietary libraries that do not normally accompany the operating system. Such a contradiction means you cannot use both them and the Library together in an executable that you distribute.

7. You may place library facilities that are a work based on the Library side-by-side in a single library together with other library facilities not covered by this License, and distribute such a combined library, provided that the separate distribution of the work based on the Library and of the other library facilities is otherwise permitted, and provided that you do these two things:

a) Accompany the combined library with a copy of the same work based on the Library, uncombined with any other library facilities. This must be distributed under the terms of the Sections above.

b) Give prominent notice with the combined library of the fact that part of it is a work based on the Library, and explaining where to find the accompanying uncombined form of the same work.

8. You may not copy, modify, sublicense, link with, or distribute the Library except as expressly provided under this License. Any attempt otherwise to copy, modify, sublicense, link with, or distribute the Library is void, and will automatically terminate your rights under this License. However, parties who have received copies, or rights, from you under this License will not have their licenses terminated so long as such parties remain in full compliance.

9. You are not required to accept this License, since you have not signed it. However, nothing else grants you permission to modify or distribute the Library or its derivative works. These actions are prohibited by law if you do not accept this License. Therefore, by modifying or distributing the Library (or any work based on the Library), you indicate your acceptance of this License to do so, and all its terms and conditions for copying, distributing or modifying the Library or works based on it.

10. Each time you redistribute the Library (or any work based on the Library), the recipient automatically receives a license from the original licensor to copy, distribute, link with or modify the Library subject to these terms and conditions. You may

not impose any further restrictions on the recipients' exercise of the rights granted herein. You are not responsible for enforcing compliance by third parties with this License.

11. If, as a consequence of a court judgment or allegation of patent infringement or for any other reason (not limited to patent issues), conditions are imposed on you (whether by court order, agreement or otherwise) that contradict the conditions of this License, they do not excuse you from the conditions of this License. If you cannot distribute so as to satisfy simultaneously your obligations under this License and any other pertinent obligations, then as a consequence you may not distribute the Library at all. For example, if a patent license would not permit royalty-free redistribution of the Library by all those who receive copies directly or indirectly through you, then the only way you could satisfy both it and this License would be to refrain entirely from distribution of the Library.

If any portion of this section is held invalid or unenforceable under any particular circumstance, the balance of the section is intended to apply, and the section as a whole is intended to apply in other circumstances.

It is not the purpose of this section to induce you to infringe any patents or other property right claims or to contest validity of any such claims; this section has the sole purpose of protecting the integrity of the free software distribution system which is implemented by public license practices. Many people have made generous contributions to the wide range of software distributed through that system in reliance on consistent application of that system; it is up to the author/donor to decide if he or she is willing to distribute software through any other system and a licensee cannot impose that choice.

This section is intended to make thoroughly clear what is believed to be a consequence of the rest of this License.

12. If the distribution and/or use of the Library is restricted in certain countries either by patents or by copyrighted interfaces, the original copyright holder who places the Library under this License may add an explicit geographical distribution limitation excluding those countries, so that distribution is permitted only in or among countries not thus excluded. In such case, this License incorporates the limitation as if written in the body of this License.

13. The Free Software Foundation may publish revised and/or new versions of the Lesser General Public License from time to time. Such new versions will be similar in spirit to the present version, but may differ in detail to address new problems or concerns.

Each version is given a distinguishing version number. If the Library specifies a version number of this License which applies to it and "any later version", you have the option of following the terms and conditions either of that version or of any later version published by the Free Software Foundation. If the Library does not specify a license version number, you may choose any version ever published by the Free Software Foundation.

14. If you wish to incorporate parts of the Library into other free programs whose distribution conditions are incompatible with these, write to the author to ask for permission. For software which is copyrighted by the Free Software Foundation, write to the Free Software Foundation; we sometimes make exceptions for this. Our decision will be guided by the two goals of preserving the free status of all derivatives of our free software and of promoting the sharing and reuse of software generally.

NO WARRANTY

15. BECAUSE THE LIBRARY IS LICENSED FREE OF CHARGE, THERE IS NOWARRANTY FOR THE LIBRARY, TO THE EXTENT PERMITTED BY APPLICABLE LAW. EXCEPT WHEN OTHERWISE STATED IN WRITING THE COPYRIGHT HOLDERS AND/OR OTHER PARTIES PROVIDE THE LIBRARY "AS IS" WITHOUT WARRANTY OF ANY KIND, EITHER EXPRESSED OR IMPLIED, INCLUDING, BUT NOT LIMITED TO, THE IMPLIED WARRANTIES OF MERCHANTABILITY AND FITNESS FOR A PARTICULAR PURPOSE. THE ENTIRE RISK AS TO THE QUALITY AND PERFORMANCE OF THE LIBRARY IS WITH YOU. SHOULD THE LIBRARY PROVE DEFECTIVE, YOU ASSUME THE COST OF ALL NECESSARY SERVICING, REPAIR OR CORRECTION.

16. IN NO EVENT UNLESS REQUIRED BY APPLICABLE LAW OR AGREED TO IN WRITING WILL ANY COPYRIGHT HOLDER, OR ANY OTHER PARTY WHO MAY MODIFY AND/OR REDISTRIBUTE THE LIBRARY AS PERMITTED ABOVE, BE LIABLE TO YOU FOR DAMAGES, INCLUDING ANY GENERAL, SPECIAL, INCIDENTAL OR CONSEQUENTIAL DAMAGES ARISING OUT OF THE USE OR INABILITY TO USE THE LIBRARY (INCLUDING BUT NOT LIMITED TO LOSS OF DATA OR DATA BEING RENDERED INACCURATE OR LOSSES SUSTAINED BY YOU OR THIRD PARTIES OR A FAILURE OF THE LIBRARY TO OPERATE WITH ANY OTHER SOFTWARE), EVEN IF SUCH HOLDER OR OTHER PARTY HAS BEEN ADVISED OF THE POSSIBILITY OF SUCH DAMAGES.

=====
 Additional Legal Notices
 =====

=====
 RapidJSON (<https://github.com/miloyip/rapidjson>) initial version (0.1) is provided under the following terms:

Copyright (C) 2011 Milo Yip

Permission is hereby granted, free of charge, to any person obtaining a copy of this software and associated documentation files (the "Software"), to deal in the Software without restriction, including without limitation the rights to use, copy, modify, merge, publish, distribute, sublicense, and/or sell copies of the Software, and to permit persons to whom the Software is furnished to do so, subject to the following conditions:

The above copyright notice and this permission notice shall be included in all copies or substantial portions of the Software.

THE SOFTWARE IS PROVIDED "AS IS", WITHOUT WARRANTY OF ANY KIND, EXPRESS OR IMPLIED, INCLUDING BUT NOT LIMITED TO THE WARRANTIES OF MERCHANTABILITY, FITNESS FOR A PARTICULAR PURPOSE AND NONINFRINGEMENT. IN NO EVENT SHALL THE AUTHORS OR COPYRIGHT HOLDERS BE LIABLE FOR ANY CLAIM, DAMAGES OR OTHER LIABILITY, WHETHER IN AN ACTION OF CONTRACT, TORT OR OTHERWISE, ARISING FROM, OUT OF OR IN CONNECTION WITH THE SOFTWARE OR THE USE OR OTHER DEALINGS IN THE SOFTWARE.

=====
 Breakpad (<https://code.google.com/p/google-breakpad/>) is provided under the following terms:

Copyright (c) 2006, Google Inc. All rights reserved.

Redistribution and use in source and binary forms, with or without modification, are permitted provided that the following conditions are met:

1. Redistributions of source code must retain the above copyright notice, this list of conditions and the following disclaimer.
2. Redistributions in binary form must reproduce the above copyright notice, this list of conditions and the following disclaimer in the documentation and/or other materials provided with the distribution.
3. Neither the name of the copyright holder nor the names of its contributors may be used to endorse or promote products derived from this software without specific prior written permission.

THIS SOFTWARE IS PROVIDED BY THE COPYRIGHT HOLDERS AND CONTRIBUTORS "AS IS" AND ANY EXPRESS OR IMPLIED WARRANTIES, INCLUDING, BUT NOT LIMITED TO, THE IMPLIED WARRANTIES OF MERCHANTABILITY AND FITNESS FOR A PARTICULAR PURPOSE ARE DISCLAIMED. IN NO EVENT SHALL THE COPYRIGHT HOLDER OR CONTRIBUTORS BE LIABLE FOR ANY DIRECT, INDIRECT, INCIDENTAL, SPECIAL, EXEMPLARY, OR CONSEQUENTIAL DAMAGES (INCLUDING, BUT NOT LIMITED TO, PROCUREMENT OF SUBSTITUTE GOODS OR SERVICES; LOSS OF USE, DATA, OR PROFITS; OR BUSINESS INTERRUPTION) HOWEVER CAUSED AND ON ANY THEORY OF LIABILITY, WHETHER IN CONTRACT, STRICT LIABILITY, OR TORT (INCLUDING NEGLIGENCE OR OTHERWISE) ARISING IN ANY WAY OUT OF THE USE OF THIS SOFTWARE, EVEN IF ADVISED OF THE POSSIBILITY OF SUCH DAMAGE.

=====
 Jansson (<http://www.digip.org/jansson/>) version 2.5 is provided under the following terms:

Copyright (c) 2009-2013 Petri Lehtinen <petri@digip.org>

Permission is hereby granted, free of charge, to any person obtaining a copy of this software and associated documentation files (the "Software"), to deal in the Software without restriction, including without limitation the rights to use, copy, modify, merge, publish, distribute, sublicense, and/or sell copies of the Software, and to permit persons to whom the Software is furnished to do so, subject to the following conditions:

The above copyright notice and this permission notice shall be included in all copies or substantial portions of the Software.

THE SOFTWARE IS PROVIDED "AS IS", WITHOUT WARRANTY OF ANY KIND, EXPRESS OR IMPLIED, INCLUDING BUT NOT LIMITED TO THE WARRANTIES OF MERCHANTABILITY, FITNESS FOR A PARTICULAR PURPOSE AND NONINFRINGEMENT. IN NO EVENT SHALL THE AUTHORS OR COPYRIGHT HOLDERS BE LIABLE FOR ANY CLAIM, DAMAGES OR OTHER LIABILITY, WHETHER IN AN ACTION OF CONTRACT, TORT OR OTHERWISE, ARISING FROM, OUT OF OR IN CONNECTION WITH THE SOFTWARE OR THE USE OR OTHER DEALINGS IN THE SOFTWARE.

=====

libmaia (<https://github.com/wiedi/libmaia>) is provided under the following terms:

Copyright 2010 Sebastian Wiedenroth. All rights reserved.

Redistribution and use in source and binary forms, with or without modification, are permitted provided that the following conditions are met:

1. Redistributions of source code must retain the above copyright notice, this list of conditions and the following disclaimer.
2. Redistributions in binary form must reproduce the above copyright notice, this list of conditions and the following disclaimer in the documentation and/or other materials provided with the distribution.

THIS SOFTWARE IS PROVIDED BY THE AUTHOR ``AS IS" AND ANY EXPRESS OR IMPLIED WARRANTIES, INCLUDING, BUT NOT LIMITED TO, THE IMPLIED WARRANTIES OF MERCHANTABILITY AND FITNESS FOR A PARTICULAR PURPOSE ARE DISCLAIMED. IN NO EVENT SHALL THE AUTHOR OR CONTRIBUTORS BE LIABLE FOR ANY DIRECT, INDIRECT, INCIDENTAL, SPECIAL, EXEMPLARY, OR CONSEQUENTIAL DAMAGES (INCLUDING, BUT NOT LIMITED TO, PROCUREMENT OF SUBSTITUTE GOODS OR SERVICES; LOSS OF USE, DATA, OR PROFITS; OR BUSINESS INTERRUPTION) HOWEVER CAUSED AND ON ANY THEORY OF LIABILITY, WHETHER IN CONTRACT, STRICT LIABILITY, OR TORT (INCLUDING NEGLIGENCE OR OTHERWISE) ARISING IN ANY WAY OUT OF THE USE OF THIS SOFTWARE, EVEN IF ADVISED OF THE POSSIBILITY OF SUCH DAMAGE. The views and conclusions contained in the software and documentation are those of the authors and should not be interpreted as representing official policies, either expressed or implied, of the author.

=====

SimpleCrypt (https://qt-project.org/wiki/Simple_encryption) is provided under the following terms:

Copyright (c) 2011, Andre Somers All rights reserved.

Redistribution and use in source and binary forms, with or without modification, are permitted provided that the following conditions are met:

- * Redistributions of source code must retain the above copyright notice, this list of conditions and the following disclaimer.
- * Redistributions in binary form must reproduce the above copyright notice, this list of conditions and the following disclaimer in the documentation and/or other materials provided with the distribution.
- * Neither the name of the Rathenau Instituut, Andre Somers, nor the names of its contributors may be used to endorse or promote products derived from this software without specific prior written permission.

THIS SOFTWARE IS PROVIDED BY THE COPYRIGHT HOLDERS AND CONTRIBUTORS "AS IS" AND ANY EXPRESS OR IMPLIED WARRANTIES, INCLUDING, BUT NOT LIMITED TO, THE IMPLIED WARRANTIES OF MERCHANTABILITY AND FITNESS FOR A PARTICULAR PURPOSE ARE DISCLAIMED. IN NO EVENT SHALL ANDRE SOMERS BE LIABLE FOR ANY DIRECT, INDIRECT, INCIDENTAL, SPECIAL, EXEMPLARY, OR CONSEQUENTIAL DAMAGES (INCLUDING, BUT NOT LIMITED TO, PROCUREMENT OF SUBSTITUTE GOODS OR SERVICES; LOSS OF USE, DATA, OR PROFITS; OR BUSINESS INTERRUPTION) HOWEVER CAUSED AND ON ANY THEORY OF LIABILITY, WHETHER IN CONTRACT, STRICT LIABILITY, OR TORT (INCLUDING NEGLIGENCE OR OTHERWISE) ARISING IN ANY WAY OUT OF THE USE OF THIS SOFTWARE, EVEN IF ADVISED OF THE POSSIBILITY OF SUCH DAMAGE.